

Notice

Hewlett-Packard to Agilent Technologies Transition

This documentation supports a product that previously shipped under the Hewlett-Packard company brand name. The brand name has now been changed to Agilent Technologies. The two products are functionally identical, only our name has changed. The document still includes references to Hewlett-Packard products, some of which have been transitioned to Agilent Technologies.



Agilent Technologies

By internet, phone, or fax, get assistance with all your test and measurement needs.

Table 1-1 Contacting Agilent

Online assistance: www.agilent.com/find/assist

United States
(tel) 1 800 452 4844

Latin America
(tel) (305) 269 7500
(fax) (305) 269 7599

Canada
(tel) 1 877 894 4414
(fax) (905) 282-6495

Europe
(tel) (+31) 20 547 2323
(fax) (+31) 20 547 2390

New Zealand
(tel) 0 800 738 378
(fax) (+64) 4 495 8950

Japan
(tel) (+81) 426 56 7832
(fax) (+81) 426 56 7840

Australia
(tel) 1 800 629 485
(fax) (+61) 3 9210 5947

Asia Call Center Numbers

Country	Phone Number	Fax Number
Singapore	1-800-375-8100	(65) 836-0252
Malaysia	1-800-828-848	1-800-801664
Philippines	(632) 8426802 1-800-16510170 (PLDT Subscriber Only)	(632) 8426809 1-800-16510288 (PLDT Subscriber Only)
Thailand	(088) 226-008 (outside Bangkok) (662) 661-3999 (within Bangkok)	(66) 1-661-3714
Hong Kong	800-930-871	(852) 2506 9233
Taiwan	0800-047-866	(886) 2 25456723
People's Republic of China	800-810-0189 (preferred) 10800-650-0021	10800-650-0121
India	1-600-11-2929	000-800-650-1101

Service Guide

HP 8711B/12B/13B/14B RF Network Analyzers



HP Part No. 08713-90005
Printed in USA February 1995

Notice.

The information contained in this document is subject to change without notice.

Hewlett-Packard makes no warranty of any kind with regard to this material, including but not limited to, the implied warranties of merchantability and fitness for a particular purpose. Hewlett-Packard shall not be liable for errors contained herein or for incidental or consequential damages in connection with the furnishing, performance, or use of this material.

Certification



Hewlett-Packard Company certifies that this product met its published specifications at the time of shipment from the factory. Hewlett-Packard further certifies that its calibration measurements are traceable to the United States National Institute of Standards and Technology, to the extent allowed by the Institute's calibration facility, and to the calibration facilities of other International Standards Organization members.

Regulatory Information

The regulatory information is in the *User's Guide* supplied with the analyzer.

How to Use This Guide

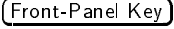
This guide uses the following conventions:

- | | |
|---|---|
|  | This represents a key physically located on the instrument. |
|  | This indicates a "softkey," a key whose label is determined by the instrument's firmware. |
| Screen Text | This indicates text displayed on the instrument's screen. |

Contents

1. Performance Tests

System Specifications Summary	1-1
Measurement Port Specifications	1-2
Source Specifications	1-2
Receiver Specifications	1-3
Performing the Operator's Check	1-5
Make a Transmission Measurement	1-6
Make a Reflection Measurement	1-7
If the Analyzer Fails the Operator's Check	1-9
Instructions for Using the Network Analyzer Performance Test Software	1-10
Introduction	1-10
Equipment	1-10
File Structure	1-12
Configuration File	1-13
Getting Started	1-13
Performance Test Software Installation	1-14
The analyzer's HP-IB address (716)	1-14
The ISC for the test equipment (7)	1-14
The power meter model number (HP 437B) and address (13)	1-14
The spectrum analyzer (HP 8566B) and address (18)	1-14
The function generator model number (HP 8116A) and address (14)	1-14
The attenuator switch driver model number (HP 11713A) and address (28)	1-15
The frequency counter model number (HP 5342A) and address (02)	1-15
The voltmeter model number (HP 3456A) and address (22)	1-15
The printer address (01)	1-15
The program directory and the mass storage unit specifier (the current MSI device)	1-15
The data directory and MSUS	1-15
The sensor's, 10 dB step attenuator's, and fixed attenuator's (pad's) serial numbers (xxxx)	1-15
The 40 dB step attenuator card selection (3)	1-15
The beeper (on)	1-15
The current DUT file suffix (1)	1-15
Sensors	1-16
20 dB Attenuators (Pads)	1-16
Step Attenuator	1-16
Using the Program	1-17
Main Menu	1-17
Test Selection Menu	1-18
Miscellaneous Information	1-19
Individual Test Notes And Descriptions	1-19
Frequency Accuracy	1-19
Gain Compression	1-19
Noise Floor	1-20
Dynamic Accuracy	1-20
Power Flatness	1-20

Absolute Accuracy	1-21
Broadband Frequency Response	1-21
Directivity (includes source match and test port match)	1-22
Spurs (including harmonics)	1-23
AM Delay Modulator (Option 1DA/1DB analyzers only)	1-23

2. Adjustments

Correction Constants (CCs) Adjustments	2-2
Fractional-N VCO Adjustment	2-3
Required Equipment	2-3
Estimated Adjustment Time	2-3
Procedure	2-3
Fractional-N Spur Adjustment	2-6
Required Equipment	2-6
Estimated Adjustment Time	2-6
Procedure	2-6
Frequency Accuracy Adjustment	2-10
Required Equipment	2-10
Estimated Adjustment Time	2-10
Procedure	2-10
Set Serial Number, Adjustment #100	2-12
Required Equipment	2-12
Estimated Adjustment Time	2-12
Procedure	2-12
In Case of Difficulty	2-13
LO Power Correction, Adjustment #101	2-14
Required Equipment	2-14
Estimated Adjustment Time	2-14
Procedure	2-14
Switched Gain Correction, Adjustment #102	2-15
Required Equipment	2-15
Estimated Adjustment Time	2-15
Procedure	2-15
External Detector Correction, Adjustment #103	2-16
Required Equipment	2-16
Estimated Adjustment Time	2-17
Procedure	2-17
Auxiliary Input Correction, Adjustment #111	2-18
Required Equipment	2-18
Estimated Adjustment Time	2-18
Procedure	2-18
Source Power (ALC) Correction, Adjustment #104	2-19
Required Equipment	2-19
Estimated Adjustment Time	2-19
Procedure	2-20
In Case of Difficulty	2-20
B Amplitude Correction, Adjustment #105	2-22
Required Equipment	2-22
Estimated Adjustment Time	2-22
Procedure	2-22
Transmission (B/R) Correction, Adjustment #106	2-23
Required Equipment	2-23
Estimated Adjustment Time	2-23
Procedure	2-23
AM Delay Correction, Adjustment #112	2-24

Required Equipment	2-24
Estimated Adjustment Time	2-24
Procedure	2-24
Reflection (One-Port) Correction, Adjustment #107	2-25
Required Equipment	2-25
Estimated Adjustment Time	2-25
Procedure	2-25
R* Amplitude Correction, Adjustment #108	2-26
Required Equipment	2-26
Estimated Adjustment Time	2-26
Procedure	2-26
R* Frequency Response Correction, Adjustment #109	2-27
Required Equipment	2-27
Estimated Adjustment Time	2-27
Procedure	2-27
B* Amplitude Correction, Adjustment #110	2-28
Running the B* Amplitude Correction Using the Performance Test Software (08712-10011)	2-28
Required Equipment	2-28
Estimated Adjustment Time	2-29
Procedure	2-29
Running B* Amplitude Correction Adjustment #110 from IBASIC	2-31
Required Equipment	2-31
Estimated Adjustment Time	2-31
Procedure	2-32

3. Assembly Replacement

Introduction	3-1
Required Tools	3-1
Major Assembly Removal/Replacement	3-1
A1 Front Panel Assembly Replacement	3-2
How to Remove the Front Panel Assembly	3-2
A2 CPU Board Assembly Replacement	3-4
How to Remove the CPU Board Assembly	3-4
A3 Fractional-N/Reference Assembly Replacement	3-7
How to Remove the Fractional-N/Reference Assembly	3-7
A4 Source Assembly Replacement	3-8
How to Remove the Source Assembly	3-8
A5 Receiver Assembly Replacement	3-9
How to Remove the Receiver Assembly	3-10
A6 Power Supply Assembly Replacement	3-11
How to Remove the Power Supply Assembly	3-11
A7 Display Assembly Replacement	3-12
How to Remove the Display Assembly	3-12
A8 3.5" Internal Disk Drive Assembly Replacement	3-13
How to Remove the 3.5" Disk Drive Assembly	3-13
Attenuator Replacement	3-13
AM Delay Modulator Replacement	3-13
Post Repair Procedures	3-14
How to Order Parts	3-15
Save Money by Ordering R-E (Rebuilt-Exchange) Assemblies	3-15
Save Time by Calling (800) 227-8164	3-15

4. Troubleshooting and Block Diagrams	
General Notes	4-1
Service Kit	4-2
How to Use the Extender Board	4-3
Initial Observations - Normal Power-up Sequence	4-4
Operator's Check	4-4
Category 1 Failures - Dead or No Response, No Display, Unreadable Display, or	
Error Messages on the Display	4-5
Troubleshooting A6 Power Supply Assembly Problems	4-5
Check the Rear Panel LEDs	4-5
Measure the Power Supply Voltages	4-6
Remove Assemblies	4-6
Troubleshooting Digital Group Problems	4-7
Error During Power-up	4-7
Test Status LEDs	4-9
Test Status LEDs code	4-9
Error Occurs During DSP Initialization or Calculating Coefficients	4-12
Clear the Nonvolatile SRAM	4-12
Measure the 5 MHz Reference Signal	4-12
Front Panel Problems	4-13
Other Power-Up Problems	4-13
Other Error messages	4-13
Category 2 Failures - No Error Message, but Nonfunctional Measurement	4-14
Troubleshooting the A3 Fractional-N/Reference Assembly	4-14
Check the Output Power	4-14
Phase Lock Problems	4-14
Detailed Fractional-N/Reference Troubleshooting	4-15
Troubleshooting the A4 Source Assembly	4-16
Troubleshooting the A5 Receiver Assembly	4-16
A5 Receiver Assembly Diode Replacement	4-17
Trace at ± 200 dB	4-20
Detailed Receiver Troubleshooting	4-20
Category 3 Failures - Inaccurate (but reasonably functional) Measurements	4-21
Troubleshooting Spurious Responses and Inaccurate Data	4-21
Spurious Signals	4-21
Spurs in the Data Trace	4-22
Inaccurate Data	4-22
Receiver Power Problems	4-23
Category 4 Failures: Peripheral Device Problems	4-24
DIN Keyboard	4-24
RS-232 Printers and Plotters	4-24
Centronics [®] (Parallel) Printers and Plotters	4-24
HP-IB Systems	4-25
HP-IB Problems with Printers or Plotters	4-25
HP-IB Problems with Disk Drives	4-25
General Checks for HP-IB Systems	4-25

5. Service Related Menus	
Introduction	5-1
Tests and Adjustments Menu	5-3
Select Self-Test Menu	5-3
Select Adjustment Menu	5-5
Instrument Info	5-7
Update Corr Const Menu	5-7
Service Utilities Menu	5-8
Meas Cal Options Menu	5-10
Analog Bus Menu	5-10
More SVC Utilities Menu	5-12
View Array Master Menu/View Array Interpol Menu	5-12
Miscellaneous Service Functions	5-13
Clearing Nonvolatile Memory (SRAM)	5-13
HP-IB Command Reference for Service	5-13
Syntax Summary	5-13
Softkey SCPI Commands	5-14
Alphabetical SCPI Command Summary	5-15
6. Theory of Operation	
Introduction	6-1
System Theory	6-1
Analyzer Functional Group	6-2
Power Supply Theory	6-2
Digital Control Theory	6-2
A1 Front Panel Assembly	6-2
A2 CPU Assembly	6-2
A7 Display Assembly	6-3
A8 3.5" Internal Disk Drive Assembly	6-3
Source Theory	6-4
A3 Fractional-N/Reference Assembly	6-4
A4 Source Assembly	6-4
Receiver Theory	6-6
Differences Between the HP 8711B/12B and HP 8713B/14B (1300 MHz vs 3000 MHz)	6-7
HP 8713B/14B A4 Source Assembly	6-7
A5 Receiver Assembly	6-8
7. Parts List	
Analyzer Hardware	7-1
Specific Assembly and Cable Locations	7-1
8. Correction Constants and Firmware	
Storing and Recalling Correction Constants (CC)	8-1
To Permanently Store CCs in the Analyzer	8-2
To Store CCs to Disk for Archive	8-2
To Recall CCs from Disk	8-2
To Recall Previous CCs from a Disk after Replacing the A2 CPU Board	8-2
To Replace Suspected Incorrect CCs	8-2
If ROM Appears to be Blank Message is Displayed at Power-up	8-2
If Warning: No Correction Constants Installed Is Displayed at Power-up	8-2
Step 1. Storing Correction Constants to Disk	8-3
Step 2. Updating or Restoring Firmware	8-4
Step 3. Installing Correction Constants from Disk	8-4
Step 4. Loading Correction Constants from Disk	8-4

Upgrading Firmware	8-4
Making a Current Correction Constants Disk (Optional)	8-5
How to Upgrade the Firmware	8-5

9. Previous Serial Numbers

10. Safety, Warranty, and Assistance

Safety Symbols	10-1
General Safety Considerations	10-2
Safety Earth Ground	10-2
Servicing	10-2
Warranty	10-3
Limitation of Warranty	10-3
Exclusive Remedies	10-3
Assistance	10-4
Shipment for Service	10-4

Index

Figures

1-1. Equipment Setup for Transmission Measurement	1-6
1-2. Typical HP 8713B/14B Transmission Measurement	1-6
1-3. Typical HP 8713B/14B Reflection Measurement	1-7
1-4. Connect the Load	1-7
2-1. Removing the Handles and Front Panel	2-4
2-2. TP11 and L162 for Fractional-N VCO Adjustment	2-5
2-3. Removing the Handles and Front Panel	2-7
2-4. Setup for Fractional-N Spur Adjustments	2-8
2-5. API and 100 kHz Adjustments	2-9
2-6. Setup for Frequency Accuracy Adjustment	2-10
2-7. Removing the Handles and Front Panel	2-11
2-8. External Detector Connector, Front View	2-16
2-9. Setup for Source Power Correction	2-20
2-10. Setup for B* Amplitude Correction for 50Ω Analyzers	2-29
2-11. Setup for B* Amplitude Correction for 75Ω Analyzers	2-29
3-1. Removing the Handles and Front Panel Assembly	3-2
3-2. Removing the CPU Assembly	3-4
3-3. BootROM U82, Component Location	3-5
3-4. Removing the Fractional-N/Reference Assembly	3-7
3-5. Removing the A4 Source Assembly	3-8
3-6. Anchoring Screw Locations for A5 Receiver Removal	3-10
3-7. A8 Disk Drive Jumper Configuration	3-13
4-1. Example of an Antistatic Workstation	4-2
4-2. Connecting the Extender Board	4-3
4-3. Power Supply Connector, as Viewed from Rear Panel	4-6
4-4. HP 8711B/12B Reflection Measurement with Through Cable	4-16
4-5. HP 8713B/14B Reflection Measurement with Through Cable	4-17
4-6. HP 8711B/12B A5CR1, CR2, CR36, and CR37 Component Locations	4-18
4-7. HP 8713B/14B A5CR45, CR46, CR47, CR48, CR53, and CR54 Component Locations	4-19
4-8. HP 8711B/12B Overall Block Diagram	4-27
4-9. HP 8713B/14B A4 Source and A5 Receiver Assemblies Block Diagram	4-29
5-1. The Service Key Menus	5-2
6-1. Simplified Analyzer System Block Diagram	6-1
6-2. Simplified HP 8711B/12B A4 Source Block Diagram	6-5
6-3. Simplified Receiver Block Diagram	6-6
8-1. Correction Constants Flow by Keystroke and Cycling Power	8-1

Tables

1-1. Required Equipment for the Adjustments and Performance Tests	1-11
3-1. Post Repair Procedures	3-14
4-1. HP 8711B/12B/13B/14B Self-Tests	4-9
4-2. Source Frequency Versus Fractional-N Frequency	4-15
5-1. HP 8711B/HP 8712B/HP 8713B/HP 8714B Self-Tests	5-4
5-2. HP 8711B/12B/13B/14B Network Analyzer Adjustments	5-6
5-3. HP 8711B/12B/13B/14B Correction Constant Storage Arrays	5-9
5-4. Analog Bus Nodes	5-11
5-5. Softkey SCPI Commands	5-14
5-6. Alphabetical SCPI Command Summary	5-15
7-1. HP 8711B/12B Major Assembly and Cable Locations	7-2
7-2. HP 8713B/14B Major Assembly and Cable Locations	7-3
7-3. A1 Front Panel Assembly and Cable Locations	7-4
7-4. A2 CPU Assembly and Cable Locations	7-5
7-5. A3 Fractional-N/Reference Assembly and Cable Locations	7-6
7-6. HP 8711B/12B A4 Source Assembly and Cable Locations	7-7
7-7. HP 8713B/14B A4 Source Assembly and Cable Locations	7-8
7-8. HP 8711B/12B A5 Receiver Assembly and Cable Locations	7-9
7-9. HP 8711B/12B A5 Receiver Optional Configurations Assembly and Cable Locations	7-10
7-10. HP 8713B/14B A5 Receiver Assembly and Cable Locations	7-11
7-11. HP 8713B/14B A5 Receiver Optional Configurations Assembly and Cable Locations	7-12
7-12. A6 Power Supply Assembly and Cable Locations	7-13
7-13. A7 Display Assembly and Cable Locations	7-14
7-14. Cabinet and Miscellaneous Parts	7-15
8-1. Storing and Recalling Correction Constants Quick Reference	8-3
10-1. Hewlett-Packard Sales and Service Offices	10-5

Performance Tests

This chapter is divided into three parts:

- the system specifications summary,
- performing the operator's check, and
- instructions for using the network analyzer performance test software.

The operator's check can be used as a quick 80% confidence test. The only equipment required for this check is a type-N cable and a good quality 50 Ω type-N load (75 Ω for option 1EC).

The performance tests will verify that the analyzer meets its published specification with greater than a 95% confidence level. The performance tests are completely automated. The performance test software is written for an HP 9000 Series 200 or 300 computer (or equivalent) using HP BASIC. There are no manual tests provided, nor are any test record cards provided.

Note If you would like to order the network analyzer performance test software (HP part number 08712-10011), contact your nearest Hewlett-Packard sales and service office.

Results of the automated performance tests can be printed out at any time. They include all specifications, limits, and uncertainties. Although no manual test is provided, each test is described in enough detail below to allow a knowledgeable technician to perform all needed tests in an accurate manner.

System Specifications Summary

The specifications and characteristics in this section describe the system performance of the analyzer.

This section is a summary of the full System Specifications. For a complete listing of the analyzer's specifications, see "Specifications and Characteristics" in the *User's Guide*.

Specifications (indicated by boldface type) describe the analyzer's warranted performance over the temperature range of 25°C \pm 5 °C, unless otherwise stated.

Supplemental characteristics (indicated by italics) are typical, but nonwarranted parameters, intended to provide information useful in applying the analyzer.

Measurement Port Specifications

The following specifications describe the residual system uncertainties. These specifications apply after a user calibration has been performed and within an environmental temperature range of 25°C ±5°C, with less than 1°C deviation from the calibration temperature.

Directivity: 40 dB

Source match (reflection): 20 dB

Source match (transmission): 14 dB (HP 8711B/12B), 20 dB (HP 8713B/14B)

Load match: 18 dB

Source Specifications

Frequency

Range HP 8711B/12B HP 8713B/14B	300 kHz to 1300 MHz 300 kHz to 3000 MHz
Accuracy	±5 ppm at 25 °C ±5 °C <1 Hz at 10% change in line voltage

Output Power

Level Accuracy¹	±1.0 dB ±1.5 dB (Option 1EC, 75Ω) ±2.0 dB (Option 1E1, Attenuator) ±3.0 dB (Options 1EC and 1E1)
-----------------------------------	---

¹ All power characteristics for HP 8713B/14B analyzers with option 1EC (75Ω ports) are typical above 2000 MHz.

Maximum Test Port Power

Frequency	HP 8711B/12B (Std)	HP 8713B/14B (Std)
≤1000 MHz	+16 dBm ¹	+10 dBm ¹
>1000 MHz	+13 dBm ¹	+10 dBm ¹

¹ Subtract from the above maximum levels the sum of: 3 dB for 75Ω (Option 1EC), 1 dB for attenuator (Option 1E1), 2 dB for AM delay (HP 8711B/12B Option 1DA/1DB), and 4 dB for AM delay (HP 8713B/14B Option 1DA/1DB)

Source Harmonics

Frequency	HP 8711B/12B	HP 8713B/14B
<1 MHz	<-20 dBc	<-30 dBc
≥1 MHz	<-30 dBc	<-30 dBc

Signal Purity

Parameter	HP 8711B/12B	HP 8713B/14B
<i>Nonharmonic Spurious</i>		
<i>≥50 kHz from carrier</i>		
<1 MHz	<-20 dBc	<-30 dBc
≥1 MHz	<-30 dBc	<-30 dBc
<i><50 kHz from carrier</i>	<-25 dBc	<-25 dBc

Receiver Specifications

Frequency Range

Type of Detection	HP 8711B/12B	HP 8713B/14B
narrowband	0.3 to 1300 MHz	0.3 to 3000 MHz
broadband	10 to 1300 MHz	10 to 3000 MHz

Typical Frequency Response (broadband)

HP 8711B/12B	HP 8713B/14B
± 0.5 dB	± 1.0 dB

Total Power Accuracy (broadband)

<i>Total Power Accuracy = Absolute Power Accuracy + Frequency Response</i>
--

Dynamic Range (Narrowband)

Frequency	HP 8711B/12B (50Ω)	HP 8711B/12B (75Ω)	HP 8713B/14B (50Ω)	HP 8713B/14B (75Ω)
<5 MHz	>60 dB	>57 dB	>100 dB	>97 dB
≥5 MHz	>100 dB	>97 dB	>100 dB	>97 dB

Maximum Input

Type of Detection	HP 8711B/12B	HP 8713B/14B
narrowband ¹	+10 dBm	+10 dBm
broadband ²	+16 dBm	+16 dBm

1 ± 0.5 dB compression

2 at 0.55 dB compression

Absolute Power Accuracy (broadband)

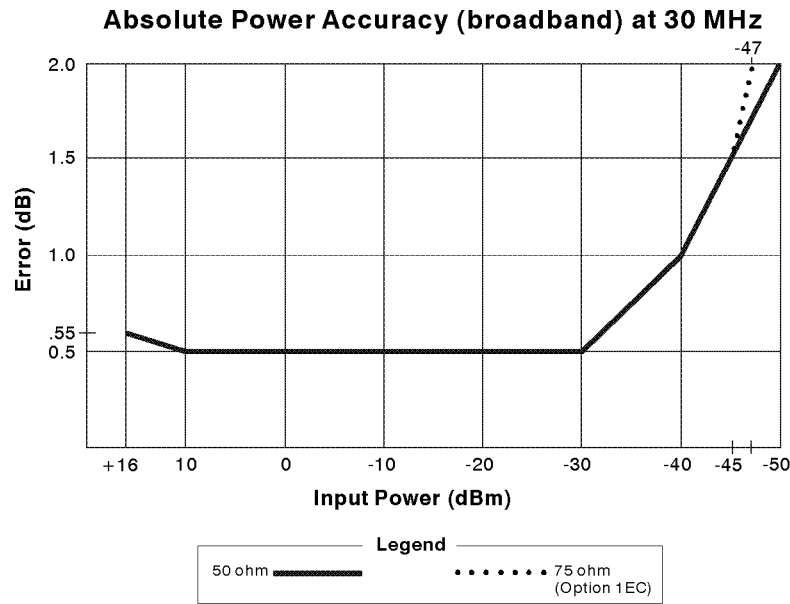

po684b_c

Dynamic Accuracy (narrowband)

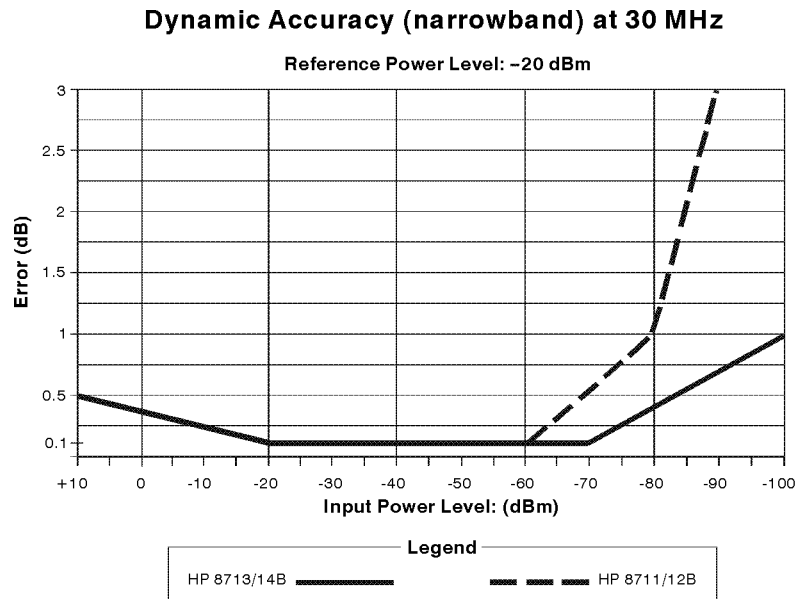

po682b_c

Performing the Operator's Check

The operator's check should be performed when you receive your analyzer, and any time you wish to be confident that the analyzer is working properly. The operator's check does not verify that the analyzer is performing to specifications. Its purpose is to provide you with a high degree of confidence that the analyzer is performing properly if it passes. The operator's check consists of making a transmission measurement with the cable that was supplied with your analyzer, a reflection measurement with the same cable, and a measurement with a 50 Ω (or 75 Ω) termination. Use a known-good load, such as one from calibration kit HP 85032B/E (50 Ω) or HP 85036B/E (75 Ω).

Make a Transmission Measurement

1. Connect the equipment as shown in Figure 1-1. Use a known good cable such as the one that was supplied with your analyzer.

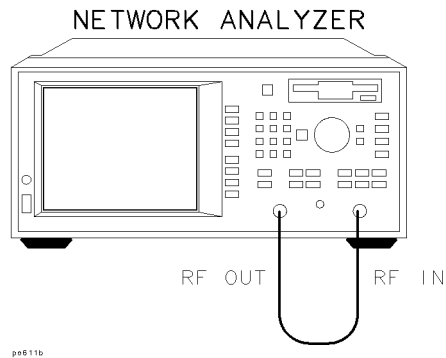

Figure 1-1. Equipment Setup for Transmission Measurement

2. Press **PRESET** **SCALE** **1** **Enter**.
3. Verify that the data trace falls within ± 0.5 dB of 0 dB. See Figure 1-2 for a typical HP 8713B/14B result. The HP 8711B/12B should look similar, but end at 1300 MHz.

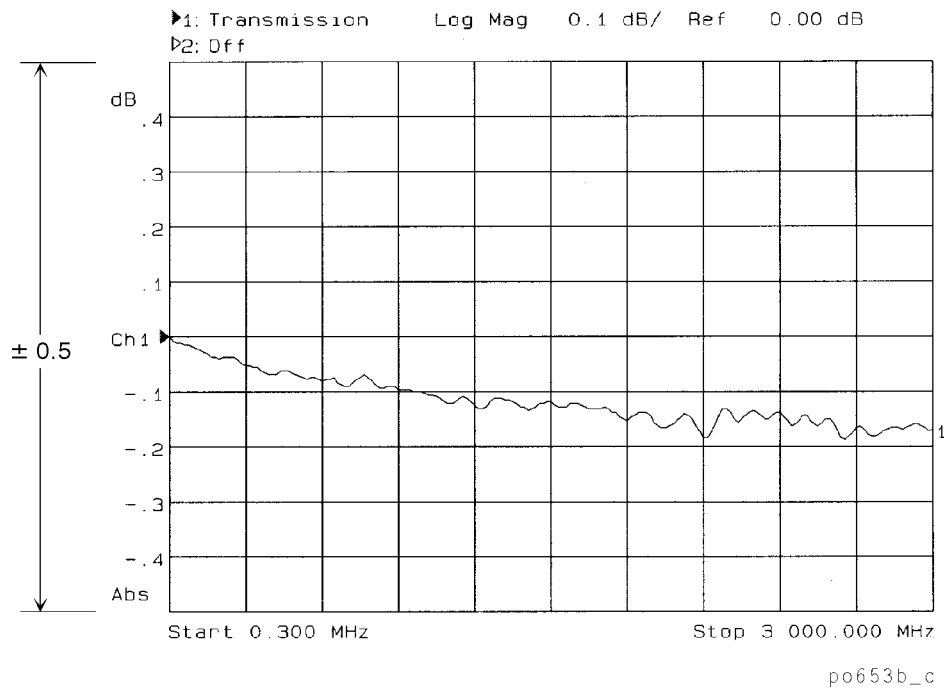

Figure 1-2. Typical HP 8713B/14B Transmission Measurement

Make a Reflection Measurement

1. Leave the cable connected to the analyzer.
2. Press **CHAN 1** **Reflection** **SCALE** **10** **Enter**.
3. Verify that the data trace falls completely below -16 dB. See Figure 1-3 for a typical HP 8713B/14B trace.

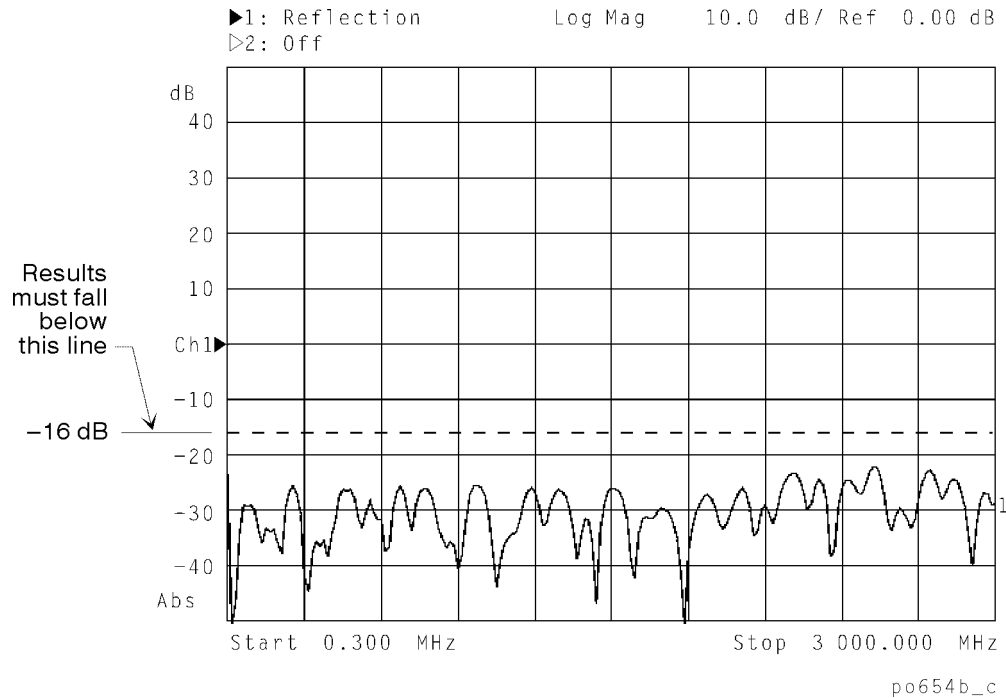

Figure 1-3. Typical HP 8713B/14B Reflection Measurement

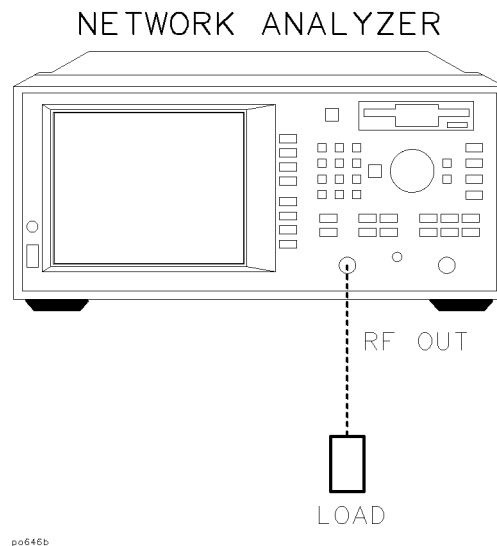

Figure 1-4. Connect the Load

4. Disconnect the cable and connect a known good load to the RF OUT port as shown in Figure 1-4.
5. Verify that the data trace falls below -30 dB. If the data trace is off the screen, press **SCALE** **Reference Level** and the **⇓** key until the trace moves up onto the screen.

This concludes the Operator's Check. However, further confidence can be obtained by performing the following:

- Measure the 175 MHz filter supplied with the analyzer to verify that its measured response is the same as is expected. Verify both the frequency accuracy and noise floor.
- Check broadband response with filter using conversion-loss mode (same as B*/R*).
- If the analyzer's frequency accuracy is critical for your application, verify a CW frequency using a frequency counter. Verify to $\pm 0.005\%$ accuracy (for example, ± 2500 Hz at 500 MHz). Ensure that the analyzer is placed in trigger-hold mode (press SOURCE **MENU** **Trigger Hold**) to measure frequencies.

If the Analyzer Fails the Operator's Check

If your analyzer does not meet the criteria in the operator's check, your analyzer may need servicing. Have a qualified service technician check the analyzer or contact any Hewlett-Packard sales or service office for assistance. Refer to Table 10-1, "Hewlett-Packard Sales and Service Offices" in "Safety, Warranty, and Assistance" for the nearest office.

Instructions for Using the Network Analyzer Performance Test Software

Introduction

The performance test software (HP part number 08712-10011) is designed to automate all the performance verification tests for the HP 8711B, HP 8712B, HP 8713B, and HP 8714B as well as the two required automated adjustments (fractional-N spur adjustment and B* amplitude correction adjustment). It will test all option combinations, including both 50Ω and 75Ω versions. An HP 9000 Series 200 or 300 (or equivalent) computer with BASIC 5.1 or greater is required to run the software. However, it will also run on a PC system with an HP BASIC language processor card (HP 82324B or equivalent).

Note This program cannot be used to test an HP 8711A. To test an HP 8711A, order HP part number 08711-10011.

The performance test software is provided on a single disk. You can run the program directly from the disk, although it is recommended that you run it from your system's hard disk for best performance. Generally, the program can be stopped, reset and re-run with little or no loss of data. The program will operate on a LIF-based system, an SRM/HFS environment, or a DOS environment.

Operation is a simple menu driven system with some softkey selections. For ease of use, the **(RETURN)**/**(ENTER)**/**(EXECUTE)** key can always be used as softkey #1: the most frequently used key.

Note All necessary instructions and test setup diagrams are contained within the program.

A disk file is generated for each analyzer, and the results of each test are stored in that file. This file is updated after each test so that results will not be accidentally lost. A printout can be obtained for any previously tested analyzer.

Test times are kept to a minimum, allowing analyzers to be fully tested within one hour.

Equipment

Besides a computer, printer, RF cables, BNC cables, HP-IB cables, and adapters, Table 1-1 lists the equipment that is required to test and adjust the analyzer.

**Table 1-1.
Required Equipment for the Adjustments and Performance Tests**

Description	HP Model #	50Ω STD		75Ω Opt 1EC		Notes
		ADJ	PERF	ADJ	PERF	
Function generator	HP 8116A	X	X	X	X	No substitute
Power meter	HP 437B, HP 438A	X	X	X	X	Do <i>not</i> use an HP 436A.
Power sensor, 50Ω	HP 8482A	X	X	X	X	
Power sensor, 75Ω	HP 8483A	-	-	-	X	
Low power sensor	HP 8481D	X	-	X	-	For option 1E1 (atten) units only
Cal kit type-N 50Ω	HP 85032B Option 001 ¹	X	X	-	-	
Cal kit type-N 75Ω	HP 85036B	-	-	X	X	
10 dB step attenuator	HP 8496A/G	X	X	X	X	
Attenuator/switch driver	HP 11713A	X	X	X	X	Needed for “G” version step attenuators only
Spectrum analyzer	HP 8560 series, HP 8566B	X	X	X	X	Others may be substituted, optional for adjustments
30 MHz bandpass filter	9135-0475	-	-	-	-	May not be required ²
20 dB attenuator 50Ω	HP 8491A/B/C Opt 020	X	X	-	-	Required for adjustments only if analyzer does not have option 1E1 installed.
20 dB attenuator 75Ω ³	0955-0758	-	-	X	X	See note for 50Ω 20 dB attenuator above.
10 dB attenuator 50Ω	HP 8491A/B/C Opt 010	X	-	-	-	May not be required for HP 8713B/14B
6 dB attenuator 50Ω	HP 8491A/B/C Opt 006	X	X	-	-	
3 dB attenuator 50Ω	HP 8491A/B/C Opt 003	-	X	-	-	
3 dB attenuator 75Ω	0955-0765	-	-	-	X	
Power splitter, 50Ω	0955-0751, 11667A	-	X	-	-	
Power splitter, 75Ω	0955-0752	-	-	-	X	
Minimum loss pad (2)	HP 11852B	-	-	X	X	One for adjustments, two for performance tests.
Frequency counter	HP 5342/3A, 5350B	-	-	-	-	May not be required. ⁴
Precision cable 50Ω	8120-4781	X	X	X	X	
Precision cable 75Ω	8120-2408	-	-	X	-	
Service kit	08712-60012	X	-	X	-	

1 An HP 85032B Option 001 is a subset of the standard HP 85032B. This eliminates two 7-mm adapters that are not needed, resulting in a significant cost savings.

2 The 30 MHz bandpass filter is used to eliminate harmonics from the external source. Its use is *not required* unless harmonics are worse than -30 dBc.

3 The 75Ω 20 dB attenuator can be substituted with two minimum loss pads and a 50Ω 10 dB attenuator. NOTE: a set of 75Ω attenuators (3,6,10,20 dB) is available as HP 86213A.

4 The frequency counter is useful when very accurate frequency measurements are needed. However, if you are using a synthesized spectrum analyzer, the frequency can be measured by using the analyzer (thus eliminating another piece of equipment). Note that the frequency measurement using a spectrum analyzer will not be quite as accurate as a frequency counter, but it is sufficient in most cases.

File Structure

The program disk contains several different files in addition to the main program file. The following list describes the files found on the performance test software disk.

CAL871XB	This is the main program file.
Cfg_XXXX	<p>This is the configuration file. The variable XXXX represents any user-defined name or Dflt (default). This file contains all the configuration set-ups for the program such as:</p> <ul style="list-style-type: none">■ file directories and paths■ test equipment serial numbers■ HP-IB addresses■ types of test equipment■ other optional choices <p>If more than one configuration file exists on the disk, the program will prompt you to select a specific configuration file to load. If none exists, the program will create a default file.</p>
P1D_XXXX	The cal factor file for the HP 8481D sensor. The variable XXXX represents the last four digits of the HP 8481D or HP 8484A sensor's serial number.
P2A_XXXX	The cal factor file for the HP 8482A sensor. The variable XXXX represents the last four digits of the HP 8482A sensor's serial number.
P3A_XXXX	The cal factor file for the HP 8483A sensor. The variable XXXX represents the last four digits of the HP 8483A sensor's serial number.
Stp_XXXX	The actual attenuation values for the 10 dB step attenuator. The variable XXXX represents the last four digits in the attenuator's serial number. Attenuator values are measured at 30 MHz on an accurate system (such as an HP 8902A Option 050).
Pd5_XXXX	The actual value of the 20 dB 50Ω attenuator as measured by an accurate system. Values are attenuation versus frequency. The variable XXXX represents the last four digits in the attenuator's serial number.
Pd7_XXXX	The actual value of the 20 dB 75Ω attenuator as measured by an accurate system. Values are attenuation versus frequency. The variable XXXX represents the last four digits in the attenuator's serial number.
d11BXXXX	The data file that holds the analyzer's test results (in this case an HP 8711B). The variable XXXX represents the last four digits in the analyzer's serial number. The file "d12BXXXX" holds data for an HP 8712B, "d13BXXXX" for an HP 8713B, etc.
CurrDUTx	The data file that holds the test results of the most recently tested analyzer regardless of model or serial number. The variable x can represent any character 0 to 9.
INSTALL	This program is not needed but will help speed the installation of the program. It will automatically copy the required files into the desired location.

Note

Several data files are present on the disk with the “xxxx” suffix. These are default files that allow operation of the program with NO correction factors. The values in these file are nominal values. For example: 100 percent for all sensor cal factors; 20 dB for the 20 dB attenuators; 10.00, 20.00, 30 . . . dB for the step attenuator, and so on. This is provided as a convenience only to demonstrate or learn about the program. The default configuration file will access these files if no user-defined serial number is specified. A warning message will be displayed if the program is using these default files.

Configuration File

The configuration (config) file is the file that customizes this program for your usage. It contains specific information for your setup. Some of the items contained in this file include:

- the HP-IB addresses of all the test equipment
- the HP-IB address of the network analyzer under test
- the model numbers of the test equipment
- the serial numbers of sensors, fixed attenuators, and the 10 dB step attenuator
- the disk drive locations (path and directories)
- other items specific to your setup

Ideally, only one configuration file should exist on the program disk so that the program will automatically load only that file. However, it is possible to have several configuration files stored on the same disk. In this case, the program will list all of the available files and prompt you to select one. This is useful if more than one setup is commonly used or if one performance test software disk serves several workstations.

Getting Started

Caution

IMPORTANT: Make a copy of the performance test software disk for day-to-day use. The master copy should remain stored in a safe place. This will decrease the likelihood of damage to the master disk.

First, find all serial numbers of the calibration devices required, such as step attenuators, sensors, and fixed attenuators for both 50Ω and 75Ω devices (if applicable). Verify the HP-IB addresses you will be using, as well as the mass storage directories and locations.

If you plan to operate this program only from the supplied floppy disk, insert the disk into the computer’s disk drive and skip step 1 below.

Performance Test Software Installation

1. To install this program to the hard drive: either copy all files (except “INSTALL”) to the hard drive, or load and run the “INSTALL” program. The INSTALL program will automatically copy all required files to your specified destination drive or directory (HFS, SRM or LIF format).

Note Any directory used must be less than 80 characters long, and preferably less than 60 characters, for best visibility.

2. Set the computer’s MSI to the directory or drive location of the main program file (CAL871XB).
3. Load and run this program. The program will display the initial screen with the software part number, revision date and current time/date. If the current time or date is incorrect, select the **SET TIME** softkey to set it.
4. Press **RESUME**. Remember, the **(RETURN)** key can also be used as softkey #1.
5. Press **CONFIG** to enter the configuration screen.

This menu allows you to enter all the specific information that pertains to your particular configuration (such as test equipment, addresses, and serial numbers). The configuration file’s selection descriptions and their initial default values are listed below.

Note In the following section, the default values for the parameters listed in bold type appear in parenthesis.

The analyzer’s HP-IB address (716). The first selection is the analyzer (DUT) HP-IB address. Please note that this is the only address that has both the Interface Select Code (ISC) and the device number associated with it. This address can be any valid address with any valid ISC. The ISC does *not* have to be the same as all the other test equipment (which must be all on the same ISC). Generally the full address for the DUT is set to either 716 or 816. This also sets the ISC to 7 or 8 respectively. The factory default HP-IB device address for the analyzer is 16.

The ISC for the test equipment (7). The second selection is the ISC for all the associated test equipment. This is generally 7 or 8 and may be the same as that for the DUT.

The power meter model number (HP 437B) and address (13). The next two selections are for the power meter model number and address.

Caution The program will accept the HP 436A power meter as a valid selection, but it is not recommended or supported and may cause the program to halt execution.

The spectrum analyzer (HP 8566B) and address (18). Next is the spectrum analyzer selection. Any of the listed models will suffice, but keep in mind that if you do not use a frequency counter, then the spectrum analyzer must have high degree of frequency accuracy since it will be used as the frequency counter.

The function generator model number (HP 8116A) and address (14). The next selection is for the function generator and address. The HP 8116A is the only valid selection at this time.

The attenuator switch driver model number (HP 11713A) and address (28). Next is the attenuator switch driver selection and address. At this time, the only two choices are the HP 11713A and 'NONE'. If 'NONE' is selected, the program will prompt you to manually set the 10 dB step attenuator each time it needs to be changed. Since this is inconvenient, the use of an HP 11713A with a HP 8496G model attenuator is highly recommended.

The frequency counter model number (HP 5342A) and address (02). The frequency counter model number and its address are next. If 'NONE' is selected, the program will use the spectrum analyzer to measure frequency accuracy.

The voltmeter model number (HP 3456A) and address (22). While the voltmeter and address are next, they are not currently used by this program.

The printer address (01). The printer address is next. No model number is needed here; all HP-IB printers should work equally well.

The program directory and the mass storage unit specifier (the current MSI device). The program directory and Mass Storage Unit Specifier (MSUS) are next. These should point to the location of the CAL871XB program and all of its required data files (all the files contained on the disk). If you are running this program from a floppy disk, the program directory entry should be blank. If using an HFS or SRM system, the entire directory name should be entered here (e.g. /TESTS/ANALYZER/NETWORK/8713B). The entire length must be less than 80 characters (preferably less than 60 for easier viewing). The MSUS, which indicates the physical address of the disk drive, also has an 80-character limit. When the program is first run, the default will be the current MSI device.

The data directory and MSUS. The next two entries are the data directory and MSUS. These should point to the location where the results of each DUT will be stored (if applicable). The data directory and MSUS are otherwise similar to the program directory, including the defaults.

The sensor's, 10 dB step attenuator's, and fixed attenuator's (pad's) serial numbers (xxxx). Six of the next seven entries will contain the LAST FOUR digits of the serial numbers for the power meter sensors, the step attenuator, and the 20 dB attenuators. This allows the program to load the proper correction values for each device.

The disk contains files that match these default serial numbers (xxxx), but the correction data contained within these files is invalid (e.g. 100 percent for all sensor cal factors). This allows the program to be run for experimental or training purposes only. As a precaution, a warning message will be displayed if a default file is loaded.

The 40 dB step attenuator card selection (3). One of the next selections is the 40 dB step section. This specifies which of two 40 dB attenuator card sections of the HP 8496G step attenuator is to be used. The HP 8496G can use either one of the two 40 dB sections; section 3 or 4. Enter the value (3 or 4) for which you have calibration data.

For example, when the step attenuator was calibrated, one of the two 40 dB sections was selected for the 40 dB attenuation value. The data corresponding to the selected 40 dB section must be input to ensure valid measurement data when using attenuations of 40 dB or greater. For purposes of identification, section 3 of the attenuator is the section that is engaged when button #3 or #7 of the HP 11713A is lit.

This entry is not applicable if you are using a manual attenuator.

The beeper (on). The last selection will suppress or enable the beeper, as desired.

The current DUT file suffix (1). This file, "CurrDUTx," contains the test-result data of the current device under test. Up to ten different file names can be specified. This allows multiple users to operate from one system storage medium, such as an SRM environment. This entry can be ignored for single-user applications.

6. Once all desired changes have been made, the program will ask if you want to store the data just entered. A specific 4-character file name suffix can be provided if more than one configuration is required. Leaving the file name blank will result in the default file name of "Cfg_dflt". If the program finds only one config file, that file will be loaded automatically. If more than one is discovered, the program will list the file names found and allow you to choose one. At this point the program will also ask you if a hardcopy printout is desired.
7. After the config file has been generated, the proper data files containing the correction values must be generated. Press `CAL DATA ENTRY`. You will be shown a list including:
 - 3 sensors
 - a step attenuator
 - two 20 dB attenuators (pads)

You will need to enter the correction data for every piece of test equipment included in this list that you will be using to test the analyzer. Select the desired item.

Sensors. All sensors require both frequency and cal factor data. Frequencies must always be in MHz and cal factors in percent. The first entry requested will be the last four digits of the serial number. The computer will search for a current configuration file containing this information. If one is present, the program will query you to either view or edit the old values.

Assuming you are editing the data, the 50 MHz reference cal factor will be requested next. This value must use percent as its units and be within the range of 50 and 150 percent.

After the cal factor is entered, the program will request that all frequency/cal factor pairs be entered. You must start with the lowest frequency for which you have data and sequentially enter higher frequencies until done. Each entry must consist of both a frequency in MHz and the cal factor in percent, separated by a comma (e.g. 500,98.6). Each frequency entered must be higher than the previous entry. These cal factor values must be between 75 and 125 percent. If a mistake is made, you can back up one entry and re-enter a value by entering a negative frequency. If you accidentally enter only the frequency (instead of a frequency/cal factor pair), the computer will wait for the cal factor to be entered; however the only prompt will be a "?".

Each entry is shown on the CRT. When all entries are completed, enter "0,0" to exit the data entry portion of the program. At this point the program will re-display all values entered and ask if you want to store them.

Note Even if you find a mistake, it will be easier to answer yes, then go back and re-edit the values, otherwise you will have to re-enter all values again.

20 dB Attenuators (Pads). A procedure similar to the sensor data entry procedure previously described is used to enter the frequency/attenuation values for the 20 dB attenuators. Valid entries for the 20 dB attenuator range from 17.5 to 23.5 dB.

Step Attenuator. Step attenuator data is only measured at 30 MHz so only one value needs to be entered for each nominal attenuation step. All values are relative to the 0 dB setting, which is defined as zero (i.e. the program does not care about insertion loss at the 0 dB setting).

Valid entries are within 3 dB of the nominal attenuation setting. The program will request data up to 110 dB of attenuation.

Using the Program

Note Remember that the **RETURN**/**ENTER**/**EXECUTE** key can be used as softkey #1.

When the program is first run, the initial information screen is presented. This contains the program name, revision number, date and other miscellaneous information. You are presented with four softkey choices: **RESUME**, **SET TIME**, **HELP**, and **EXIT**.

SET TIME allows you to set the time and date. If the date has never been set, the program will force you to enter it regardless of whether or not this softkey is pressed.

HELP will present some very brief instructions and other information.

EXIT will terminate the program.

RESUME will continue execution of the program and proceed to the main menu.

Main Menu

The main menu provides seven softkey choices. An eighth choice may be displayed if you are returning to this menu from the test selection menu.

CONFIG allows you to define a particular configuration of test equipment, mass storage, and HP-IB addresses. This selection is described earlier in "Configuration File."

LOAD CONFIG allows you to select one of several configurations to choose from. If only one is available, it is automatically loaded without further confirmation. If several are available, you are instructed to select one.

CAL DATA ENTRY allows you to enter correction factors for sensors, attenuators and attenuators. See "Configuration File," earlier in this chapter.

PRINT RESULTS allows you to print or view test results from the current DUT or any previously tested analyzer, assuming the data was archived. You can also add comments or correct any header information that was previously entered.

NEW DUT will appear only after an analyzer has been tested. This softkey must be selected *before* you begin to test another analyzer.

Note This is the only way that the program can tell that the analyzer under test has changed. Once selected, this softkey selection will disappear, indicating that the program is ready to search for a new analyzer model/serial number.

HP-IB Addr's will display the current expected addresses of all required test equipment. In addition it will allow you to check each listed address for the presence of an active device. It will not indicate which device is set to which address. It only indicates whether or not the device at a given address is capable of handshaking properly. **EXIT** returns to the previous menu.

RESUME will continue the program and look for an analyzer at the specified address. Make sure the power is switched ON and the HP-IB cable is connected before pressing **RESUME**.

Once the program finds the network analyzer, the serial number is interrogated and the disk is searched for any previous test results. If none are found, a message is displayed and you are

then allowed to enter any pertinent data regarding this new DUT such as owner, technician, repair order, comments etc. The test selection menu is then presented.

Test Selection Menu

The test selection menu can be divided into four main categories:

- Ten automated analyzer performance tests
- Two automated adjustment procedures
- Four utility procedures
- Two detector performance tests (HP 86200B or HP 86201B)

Data for each of the ten performance tests is archived upon completion. The two adjustments are the fractional-N spur adjustment and the B* amplitude adjustment. No archive data is stored for the adjustment routines.

The four utility programs are described as follows:

1. **Set Serial Number** utility allows you to enter a serial number into the analyzer. This may be required after some types of repairs.

Caution *Enter the number carefully; it cannot be easily changed once it has been entered. If a mistake is made, it will be necessary to contact an HP service center for correction.*

2. The **Step Attenuator Test** is a cyclical stress test designed to show any weakness in the mechanical (and therefore, electrical) integrity of the built-in attenuator (Option 1E1 units only). For each cycle, the attenuator card is switched in and out with each resulting trace measured. Minimum and maximum excursions are then noted. The test is performed at a low frequency and a high frequency. The number of cycles is selected by the user. A minimum of twenty-five is recommended. One hundred cycles will take about five to ten minutes depending upon computer speed. There is no pass/fail indication but trace variances of more than 0.1 dB should warrant further investigation or increased monitoring for signs of wear.
3. **Measure Step Attenuator** and **Measure 20 dB Pad** are utility files designed to use a power meter to measure the actual insertion loss at 30 MHz for both of these devices. These two routines should only be used as a last resort if no other method of obtaining this data is available. Generally these devices should be measured using one of the following methods:
 - Sending the device to a calibration standards lab
 - Measuring the device with an HP 8753D with full two-port correction
 - Measuring the device with an HP 8902A Option 050

Note The listed uncertainties shown on the test results assume that one of these three choices was used and *not* the built-in routine which has a much higher degree of uncertainty.

4. The **Detector tests** consists of an absolute power accuracy test and a frequency response test as described in the *HP 86200B/86201B RF Detectors User's and Service Guide*. These tests are only for testing these two specific detector models. Archiving of data is not done for these tests.

Miscellaneous Information

The program gives full step by step instructions along with connection diagrams. For clarity, some of the required adapters may not be depicted in the connection diagrams. Generally, solid connection lines between devices indicate a cable connection, where as a dotted line indicates a direct connection (adapters may be required). All required equipment should be connected and switched ON before proceeding with any test, since the program will occasionally need to write to a device before it is shown in the connection diagram. If the device is not connected, the program will time-out before the connection diagram is drawn. The time-out limit is set to 30 seconds for all devices. If the program should stop for any reason, the computer may be reset and the program run again with little or no loss of data (if a SCRATCH C is *not* performed).

Individual Test Notes And Descriptions

The following sections explain how each test is performed, in case it is necessary to perform them manually without a computer.

Frequency Accuracy

This test measures the frequency accuracy of the analyzer at several CW frequencies while in trigger-hold mode. The device used to measure the frequency can either be a frequency counter or a spectrum analyzer with a high degree of frequency accuracy.

Accuracy is measured to .005 percent or 5 kHz at 1000 MHz. Option 1EC analyzers (75 Ω) will require a minimum loss pad in order to connect to a 50 Ω frequency counter or spectrum analyzer.

If This Test Fails

Failures of this test are rare. If this test should fail by a small amount, readjust the reference crystal oscillator by performing the frequency accuracy adjustment. If it fails by a significant amount, and the A3 fractional-N/reference assembly's 10 MHz reference output is accurate, suspect excessive noise on the RF output of the source. See the section titled "Troubleshooting the A4 Source Assembly" in the "Troubleshooting and Block Diagrams" chapter.

Gain Compression

Gain compression is measured over the frequency range by inserting a calibrated 20 dB fixed attenuator and measuring the change with the analyzer. A 3 dB fixed attenuator and through-line cable is first connected to the ports and the power level set to 3 dBm for the HP 8713B/14B or +13 dBm (or max power) for the HP 8711B/12B. The 3 dB attenuator is used to improve any mismatch errors. The resulting power is read by the analyzer. The calibrated 20 dB fixed attenuator is then inserted into the path and the resulting power is measured again. The difference is then compared to the known insertion loss of the calibrated 20 dB fixed attenuator.

Based on known characteristics of the receiver, the power levels tested for both high and low frequency units represent the worst-case gain compression areas. It is not necessary to test gain compression up to +10 dBm on the HP 8713B/14B. Experience has shown that worst-case gain compression is generally from 0 dBm to -20 dBm. Likewise the worst case compression for the HP 8711B/12B occurs from +10 to -10 dBm. Compression is tested in a narrow (250 Hz) bandwidth.

If This Test Fails

Repeat adjustments #101 and #105. If this does not solve the problem, replace the A5 receiver assembly.

Noise Floor

The noise floor test is divided into two sections; broadband and narrowband. During this test the RF output is terminated in 50Ω or 75Ω and the RF input is shorted. For the broadband portion, the analyzer is set to measure B* with averaging ON and with a narrow bandwidth. Worst-case noise floor is then measured starting from 10 MHz. For narrowband mode, the noise floor is measured with the B input (not B/R) in a fine bandwidth (15 Hz) and spur avoid activated. This portion of the test is divided into two sections: frequencies below 5 MHz and frequencies above 5 MHz.

If This Test Fails

First verify that all cable connections and screws are secure, then repeat adjustment #102. If only the broadband portion fails, the A5 receiver diodes may be bad; see “Troubleshooting the A5 Receiver Assembly” in the “Troubleshooting and Block Diagrams” chapter for more information. Otherwise, the A5 receiver assembly is most likely bad, though spurs generated in either the A3 fractional-N/reference or A4 source assemblies can also cause noise floor failures.

Dynamic Accuracy

Dynamic accuracy is measured on the narrowband B detector at a CW frequency of 30 MHz, from 0 dBm (if possible) down to -100 dBm in 10 dB increments. A calibrated 10 dB step attenuator is used as the reference device. On 75Ω analyzers, two minimum loss pads must be used to convert the impedance to 50Ω for the HP 8496A/G attenuator. The analyzer is set to measure the B input in a fine (15 Hz) bandwidth. Power is first measured at -20 dBm and all measurements are made relative to this point (generally this means the attenuator is set to 20 dB). The attenuator is then switched in 10 dB increments and the resulting power is read from the analyzer. These values are then compared to the known values of the calibrated step attenuator. The difference is the dynamic accuracy error of the analyzer.

Mismatch errors are minimal since the input/output match at 30 MHz is very good. For some combinations of options on 75Ω analyzers, the 0 dBm point may not be obtainable. In this case, only levels at and below -10 dBm are tested.

If This Test Fails

First repeat adjustment #102. If the problem persists, suspect calibration errors in the step attenuator used to perform this adjustment; see “The 40 dB step attenuator card selection (3)” in “Performance Test Software Installation” earlier in this chapter. Crosstalk can also affect this test; verify that all cables and screws are secure.

Power Flatness

Power flatness is defined as the maximum variation in power at the RF output connector across the frequency range of the analyzer. If the specification is ± 1 dB then a maximum variation of 2 dB is allowed. In this test a calibrated power sensor is connected directly to the RF output. The analyzer is stepped through twenty-seven CW frequencies at one power level and each is measured and corrected based on the power sensor cal factor. The maximum variation is then compared to the specification. Several power levels are tested, ranging from the maximum specified power to the minimum specified power without using the built in attenuator (if applicable). If the analyzer has an attenuator, three more levels are tested, each one using one section of the attenuator (10 dB, 20 dB, and 30 dB). The power meter is zeroed before making any series of measurements below -19 dBm.

A second test is performed as a precaution to ensure that no power holes exist. A through cable is connected and, starting at 10 MHz, the analyzer is swept over its frequency range using 1601 points-per-sweep. The B* input is also measured and the resulting trace is checked for any significant power holes that could have been missed during the previous section of this

test. The sweep is repeated again using each section of the attenuator (if one is installed) to verify its power flatness.

If This Test Fails

Repeat the test, verifying that all connections are secure. If the test still fails, repeat adjustment #104.

Absolute Accuracy

This test verifies the accuracy of the B* input at 30 MHz from its maximum input of +16 dBm down to -50 dBm (-47 dBm for option 1EC analyzers). A separate power source is required to achieve the required power (in this case an HP 8116A function generator). A 10 dB step attenuator is used to vary to power over the full 66 dB range.

The output of the HP 8116A is sent through an optional 30 MHz bandpass filter, then to the step attenuator. A 6 dB attenuator is placed after the attenuator and a power sensor is then connected to the attenuator. The source and step attenuator are varied in 5 dB increments from +16 down to approximately -24 dBm and the resulting power is noted. For measurements below -24 dBm, the power out is calculated based on the step attenuator values. This avoids having to use a low-power diode sensor (although this would be acceptable, it is an inconvenience). Once the power levels have been measured (or calculated) using the power meter as a reference, the power sensor is disconnected and the output of the attenuator is connected to the RF input of the analyzer. The same power level conditions are then repeated and the resulting analyzer measurements are averaged and recorded.

These measurements are compared to the power meter readings and any deviations are compared to the specification. A narrow bandwidth is used for all analyzer measurements. For 75Ω analyzers, the 6 dB attenuator is replaced with a minimum loss pad. The 30 MHz filter is used to eliminate any harmonics of the 30 MHz signal. However, in most cases the filter can be eliminated. It is only required if the second or third harmonic of the HP 8116A is worse than -30 dBc.

If This Test Fails

First verify that the correct 40 dB section of the attenuator is being used (if applicable). See “The 40 dB step attenuator card selection (3)” in “Performance Test Software Installation” earlier in this chapter.

If this is okay, repeat adjustment #110. If the test still fails, the cause is most likely damaged A5 receiver diodes. See “Troubleshooting the A5 Receiver Assembly” in the “Troubleshooting and Block Diagrams” chapter for more information.

Broadband Frequency Response

This test checks the broadband frequency response of the B* input at a nominal -6 dBm input to the analyzer. The RF output of the analyzer is sent to the input of a power splitter. One output of the splitter is sent to the RF input of the analyzer while a power sensor is connected to the other output. The analyzer is stepped through a cycle of CW frequencies while the analyzer’s source power and the corrected power meter reading are noted. Once this has been done, the two connections to the outputs of the power splitter are swapped, and the process is repeated. This eliminates any differences within the power splitter. The two readings for each frequency point are averaged and the averaged analyzer data is compared to the averaged power meter data. Both sets of data are subtracted from a 30 MHz reference point. Variations in response are then relative to this point. For 75Ω analyzers the power splitter and sensor must also have a 75Ω input impedance. Adapters are generally required for this test. If necessary, three-way power splitters can be substituted for two-way power splitters, as long as the unused port is terminated in its characteristic impedance. Power dividers or splitters can be used interchangeably with minimal measurement degradation.

If This Test Fails

Repeat the test after verifying that all connections are secure. There is no corresponding adjustment for this test. Verify that the A5 receiver assembly's detector diodes are functioning properly. See "Troubleshooting the A5 Receiver Assembly" in the "Troubleshooting and Block Diagrams" chapter for more information.

Directivity (includes source match and test port match)

These tests require an HP 85032B (standard or option 001) calibration kit for a 50 Ω analyzer or an HP 85036B calibration kit for a 75 Ω analyzer.

Note The standard economy (E) versions of these kits do *not* provide the necessary components to perform this procedure.

Directivity is measured by presetting the analyzer, then attaching a known-good load to the RF output and performing a reflection measurement. This measures the default calibration of the analyzer. This value is characteristically 30 dB. A user calibration will provide 40 dB of directivity, but for this test, we are testing only the quality of the default calibration. The typical specification is 30 dB. The program prompts you through all portions of the test and displays the results on the screen of the analyzer.

Source match is measured at the same time as directivity. This test can be performed manually by taking the following steps:

1. Switch **Meas Cal on OFF** under the **Meas Cal Options** portion of the service menu to disable correction.
2. Perform a one-port reflection calibration.
3. View the **Source Match** array under the **View Array Master** portion of the **Meas Cal Options** menu.

Raw directivity can also be viewed by selecting the corresponding softkey. Do not confuse this with the default directivity above; raw directivity will be much lower.

Input port match is measured by performing a one-port cal at the end of a type-N cable using the female standards contained in the cal kit. For this reason, the economy version of the cal kits cannot be used since they do not contain female standards. Once the user cal is completed the cable is attached to the RF input port and the input match is measured. Please note that when the female open is called for during this user calibration, the extender pin must be placed over the center conductor of the cable.

If This Test Fails

Directivity is mostly dependent upon:

- the quality of adjustment #107
- the quality of reference load used in the adjustment
- the quality the load used in the test

If directivity should fail, repeat adjustment #107 with a known good load (better than 40 dB of return loss). Source match is mostly dependent upon hardware in the A5 receiver assembly. Any failures will probably require the replacement of the A5 receiver assembly.

Test port match is solely dependent upon the A5 receiver assembly. If either of these two tests fail, first inspect the two type-N connectors for damage, especially on 75 Ω units. If the test port match fails, also suspect the A5 receiver assembly diodes.

Spurs (including harmonics)

Harmonics and spurs are tested by connecting the analyzer to a spectrum analyzer via a high quality type-N cable. For 75 Ω analyzers, a minimum loss pad is used to change the impedance to 50 Ω . The loss through the cable is compensated for automatically. Harmonics are tested at +7 dBm minus the sum of:

- 3 dB for option 1EC
- 1 dB for option 1E1
- 2 dB for HP 8711B/12B option 1DA/1DB
- 4 dB for HP 8713B/14B option 1DA/1DB

In-band harmonics are tested at several frequencies. The second harmonic of 700 MHz need not be tested on an HP 8711B/12B because its upper frequency is 1300 MHz. Out-of-band harmonics are not tested.

Fractional-N spurs are also tested with this program, as well as some other types of spurs but generally none of these cause problems. These type of spurs have typical (characteristic) specifications only.

This automated test requires that the spectrum analyzer's and the network analyzer's timebases be tied together, so that any known spur will be at the exact frequency expected. Connect a BNC cable between the spectrum analyzer's EXT REF OUT to the network analyzer's EXT REF IN. This saves significant time since the program does not have to search for every signal. The program will first check that the timebases are connected together before proceeding. If this test is performed manually, locking the two analyzers together is not necessary.

If This Test Fails

Note that while many types of spurs are tested, only harmonics are specified. If harmonics should fail, repeat the fractional-N adjustment as well as adjustment #104. The most likely cause of a failure is the A4 source assembly.

AM Delay Modulator (Option 1DA/1DB analyzers only)

AM delay itself is not tested in the analyzer since it is a function of the external detector used. However the AM delay modulator is tested for functionality. When the modulator is on, any CW signal is AM modulated with a 27.78 kHz sinewave. This modulation produces sidebands on either side of the CW signal when viewed on a spectrum analyzer. This test simply looks for the sidebands to be between 22.5 and 33 dB below the CW signal level. The test is performed at several CW frequencies. 75 Ω analyzers will need a minimum loss pad for proper impedance matching. As discussed previously, the spectrum analyzer and network analyzer timebases should be connected together to avoid any frequency error.

If This Test Fails

The AM delay adjustment does *not* significantly affect this test. If this should fail, first check that the ribbon cable is securely attached to the AM delay modulator assembly. Otherwise, replace the AM delay modulator assembly.

Adjustments

This chapter contains procedures to adjust the analyzer. You need an external controller for running three of the adjustments. The remaining adjustments are accessed through the analyzer's service menus.

Refer to "Post-Repair Procedures" in the "Assembly Replacement" chapter to determine which adjustment procedures you need to do when a particular part has been replaced.

You should perform the adjustment procedures in the order given here:

1. Fractional-N VCO Adjustment
2. Fractional-N Spur Adjustment (Requires controller)
3. Frequency Accuracy Adjustment
4. Serial Number, Adjustment #100 (Requires controller or IBASIC option 1C2)
5. LO Power Correction, Adjustment #101
6. Switched Gain Correction, Adjustment #102
7. External Detector Correction, Adjustment #103
8. Aux Input Correction, Adjustment #111
9. Source Power (ALC) Correction, Adjustment #104
10. B Amplitude Correction, Adjustment #105
11. Transmission (B/R) Correction, Adjustment #106
12. AM Delay Correction, Adjustment #112
13. Reflection (One Port) Correction, Adjustment #107
14. R* Amplitude Correction, Adjustment #108
15. R* Frequency Response Correction, Adjustment #109
16. B* Amplitude Correction, Adjustment #110 (Requires controller or IBASIC option 1C2)

Items 1 through 3 above are adjustments where a physical part is changed (e.g. a potentiometer is adjusted); no correction constants are generated from these adjustments. Item 4 above (adjustment #100) does not generate a correction constant, though the data is entered into permanent memory on the A2 bootROM.

Caution Procedures 5 through 16 all generate correction constants. For proper operation, these correction constants must be handled properly. Please read the next few paragraphs carefully.

Correction Constants (CCs) Adjustments

Note Please read the next paragraphs *carefully*.

When you switch ON the analyzer's line power, the analyzer copies the current correction constants from the CPU EPROM into a RAM buffer. When you run the adjustment tests, the analyzer generates correction constants and saves them to the RAM buffer only (they are erased if the analyzer's line power is switched OFF). To transfer the newly generated correction constants from the RAM to the EPROM, perform the "Storing and Recalling Correction Constants" procedure in Chapter 8. You should also use the procedure in "Storing and Recalling Correction Constants" to make a copy of the correction constants. This allows you to quickly restore the adjustment data if you replace the CPU board or update the firmware.

When you are performing the adjustment procedures, you should periodically store the correction constants to a disk file. This allows you to restore data quickly in case you need to switch OFF the analyzer's line power before completing the adjustments.

Caution If the analyzer's line power is switched OFF at any time during the adjustments, you *must* reload the previously stored correction constants before proceeding. Failure to do so will result in loss of previously performed adjustment data. The adjustments will have to be performed again.

Fractional-N VCO Adjustment

Note The fractional-N VCO adjustment is not normally required. If this board has been replaced, the replacement board will have been adjusted at the factory. This adjustment should only be performed if you have reason to believe that the fractional-N VCO assembly is not functioning properly.

This procedure shows you how to adjust the frequency of the fractional-N VCO on the A3 fractional-N/reference assembly.

Caution Place the analyzer on an anti-static mat and wear a connecting wrist strap when making this adjustment.

Required Equipment

Equipment Description	Recommended Model or Part Number
Service extender board	part of service kit, 08712-60012
Digital voltmeter	any

Estimated Adjustment Time

This adjustment takes approximately five minutes to perform.

Procedure

1. Switch OFF the analyzer's line power. Remove the front panel by following these steps and referring to Figure 2-1:
 - a. Remove the trim strip from the handles by gently prying it off with a small flathead screwdriver.
 - b. Remove the four #15 TORX screws attaching each handle to the analyzer.
 - c. Pull the analyzer toward you until the chassis extends about two inches over the edge of the table top.
 - d. Grasp and pull the front panel with two hands: one on the top-middle of the panel, and the other on the bottom-middle of the panel. Once the front panel has been removed, disconnect the front-panel ribbon cable.
 - e. Remove the two #10 TORX screws attaching the handle nut plate on the right side.

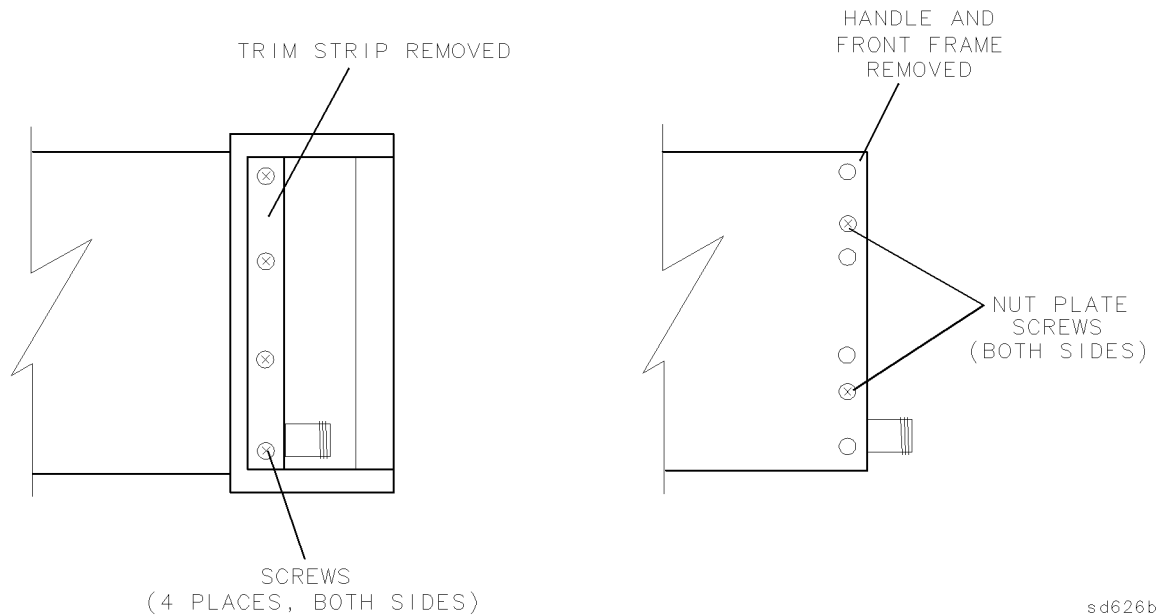

Figure 2-1. Removing the Handles and Front Panel

2. To setup the service extender board for adjusting the fractional-N board assembly, follow these steps (see also Figure 4-2):
 - a. Remove the backplane cover from the rear panel of the analyzer by unscrewing the two hold-down screws and sliding the cover toward the power-cord receptacle.
 - b. Attach the service extender board by reversing step (a) with the lower extender board assembly. Tighten the two hold-down screws securely.
 - c. Place an antistatic mat on top of the analyzer.
 - d. Remove the two SMB cables from the fractional-N/reference assembly. Remove the nut on the rear panel EXT REF BNC connector.
 - e. Use the handle tab to loosen the assembly, then pull the board assembly out of the analyzer. Attach the fractional-N/reference assembly backplane connector to the upper extender board.
 - f. Reconnect the SMB cables. If necessary, use the longer SMB cables provided in the service kit.

3. Switch ON the analyzer's line power.

If your analyzer is an HP 8711B/12B:

set the analyzer's source frequency to 1.3 GHz by pressing **PRESET** **FREQ** **CW** **1.3** **GHz**.

If your analyzer is an HP 8713B/14B:

set the analyzer's source frequency to 1.82 GHz by pressing **PRESET** **FREQ** **CW** **1.82** **GHz**.

4. Measure the voltage at TP11 with respect to ground on the fractional-N board assembly. See Figure 2-2 for the location.

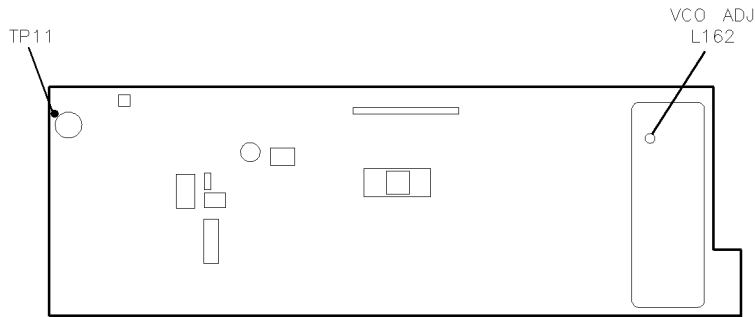

s d65b

Figure 2-2. TP11 and L162 for Fractional-N VCO Adjustment

5. Use a nonconductive adjustment tool, such as a small ceramic or plastic flatblade screwdriver, to adjust L162 (see Figure 2-2) until TP11 reads -1.17 ± 0.03 volts with respect to board ground.

Remove the adjustment tool and measure the voltage again to insure that it has not changed.

6. If you are going to make the fractional-N spur adjustment, continue to that procedure without changing the equipment setup. If you are *not* going to make the fractional-N spur adjustment, reassemble the analyzer.

Fractional-N Spur Adjustment

Note The fractional-N spur adjustment is not normally required. If this board has been replaced, the replacement board will have been adjusted at the factory. This adjustment should only be performed if you have reason to believe that the fractional-N VCO assembly is generating spurious responses.

This adjustment minimizes the spurs caused by the analog phase interpolators (APIs) on the fractional-N board assembly. An external controller sets the source output frequencies on the analyzer and sets up the spectrum analyzer to measure the spur. Afterwards, you can adjust potentiometers to minimize the spur.

Required Equipment

Equipment Description	Recommended Model or Part Number	
	50 Ω (standard)	75 Ω (opt. IEC)
HP BASIC controller w/BASIC 5.0 or higher	HP 9000 series 200/300	HP 9000 series 200/300
Test software	08712-10011	08712-10011
Spectrum analyzer	HP 8560 Series or HP 8566B	HP 8560 Series or HP 8566B
Test port cable	8120-4781	8120-4781
Minimum loss pad	N/A	HP 11852B
Service extender board	p/o service kit, 08712-60012	p/o service kit, 08712-60012

Note Before performing this adjustment:
Check the voltage at A3TP11 as described in the previous adjustment (“Fractional-N VCO Adjustment”) and adjust as required.

Estimated Adjustment Time

This adjustment takes approximately fifteen minutes to perform.

Procedure

1. If you already have the fractional-N board assembly out of the analyzer and attached to the service board extender, continue with step 4. If not, continue with the next step.
2. Switch OFF the analyzer’s line power. Remove the front panel by following these steps and referring to Figure 2-3:
 - a. Remove the trim strip from the handles.
 - b. Remove the four #15 TORX screws attaching each handle to the analyzer.
 - c. Pull the analyzer toward you until the chassis extends about two inches over the table-top.

- d. Grasp and pull the front panel with two hands: one on the top-middle of the panel, and the other on the bottom-middle of the panel. Once the front panel has been removed, disconnect the front-panel ribbon cable.
- e. Remove the two #10 TORX screws attaching the handle nut plate on the right side.

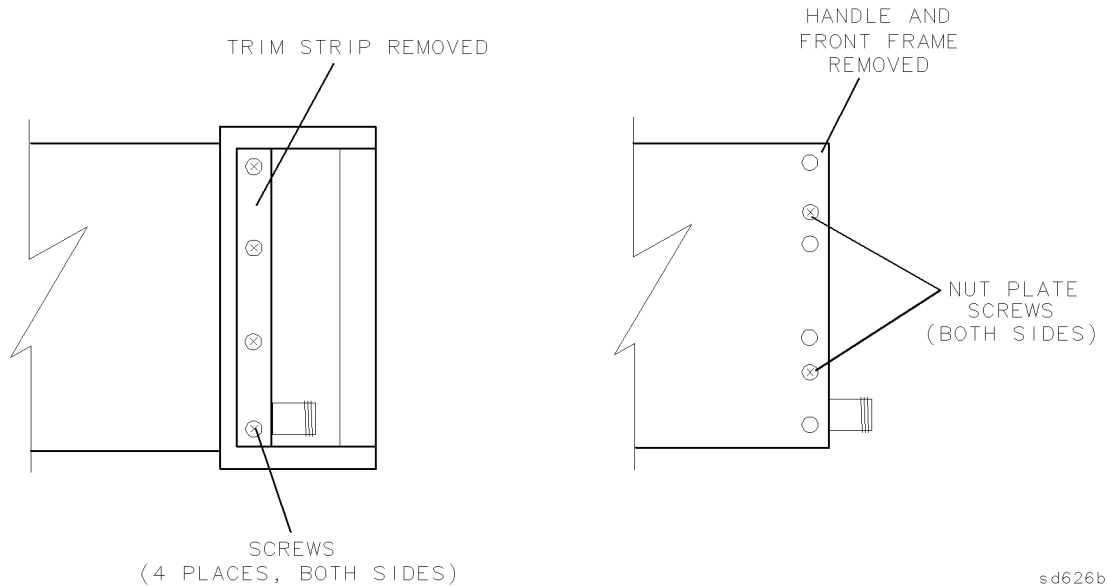
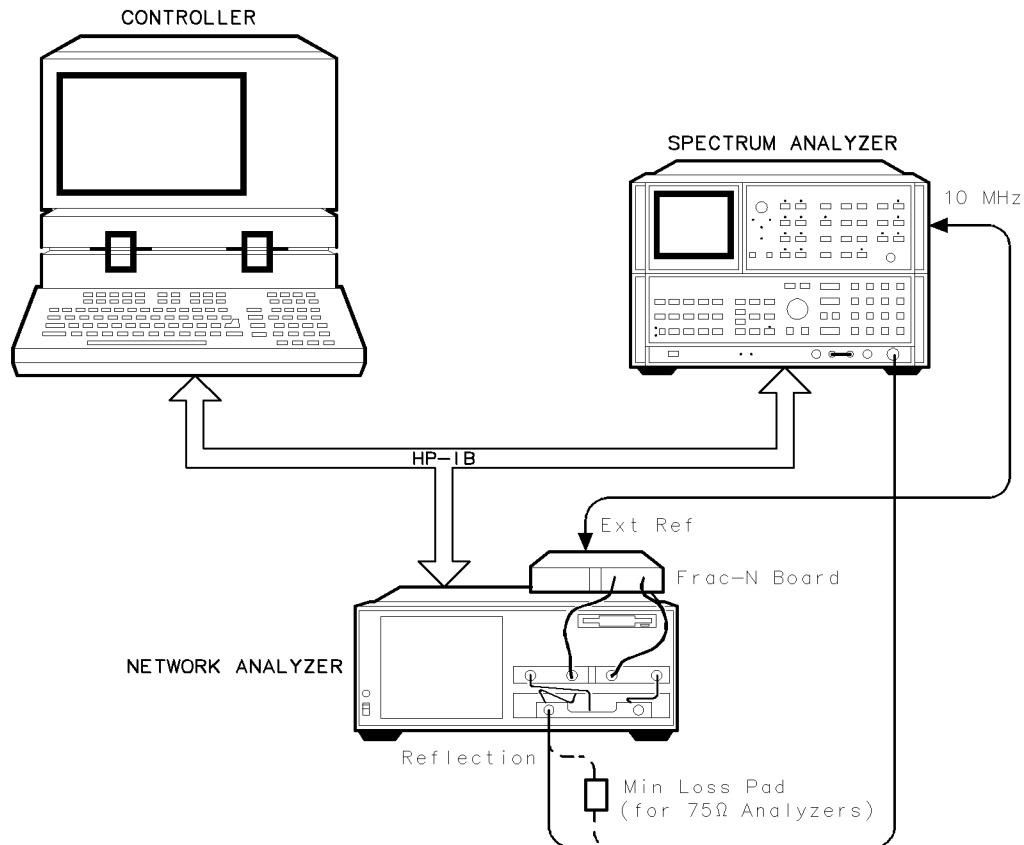

Figure 2-3. Removing the Handles and Front Panel

3. To setup the service extender board for adjusting the fractional-N board, follow these steps:
 - a. Remove the backplane cover from the rear panel of the analyzer by unscrewing the two hold-down screws and sliding the cover toward the power-cord receptacle.
 - b. Attach the service extender board by reversing step (a) with the lower extender board. Tighten the screws securely.
 - c. Place an antistatic mat on top of the analyzer.
 - d. Remove the two SMB cables from the fractional-N/reference assembly. Remove the nut on the rear panel EXT REF BNC connector.
 - e. Use the handle tab to loosen the assembly, then pull the board assembly completely out of the analyzer. Attach the fractional-N/reference assembly backplane connector to the upper extender board.
 - f. Reconnect the SMB cables. If necessary, use the longer SMB cables provided in the service kit.
4. Connect the equipment as shown in Figure 2-4.



sd612b

Figure 2-4. Setup for Fractional-N Spur Adjustments

5. Load and run the test software by following the procedure in “Loading and Running the Test Software” in the “Performance Tests” chapter of this guide.
6. Select “Fractional-N Adjustments” from the performance tests main menu.
7. For each API adjustment, the program shows spurs three times, once for each fractional-N VCO frequency. To minimize the spur, adjust the potentiometers shown in Figure 2-5.

You may have to compromise the three different adjustments of the same pot to achieve the best overall results.

Generally, the API #1 spur is the worst. When adjusting the API #2 and API #4 spurs, their amplitude may be so low that they are not visible.

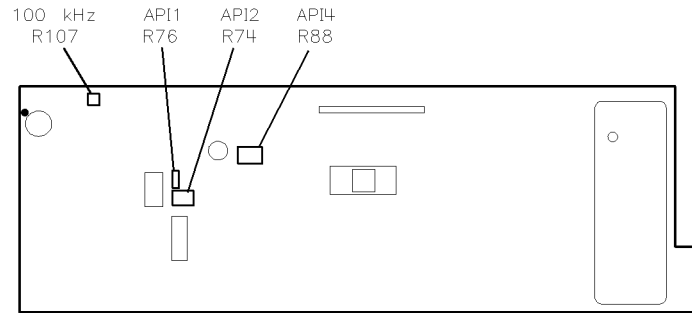

s d66b

Figure 2-5. API and 100 kHz Adjustments

8. After the API adjustment, the program prompts you to adjust for the 100 kHz spur at a single frequency. The controller displays a message, telling you when the adjustment has completed.
9. Insert the fractional-N board assembly back into the analyzer (do *not* reassemble the analyzer completely yet). Run the spurious signal portion of the performance test to verify that the API (fractional-N spurs) still pass once the assembly has been re-installed.
10. If you do not need to repeat the API and 100 kHz spurs adjustment, remove the extender board and reassemble the analyzer.

Note The spur performance of the fractional-N board may change *significantly* when you reinstall the assembly in the analyzer. If the performance deteriorates significantly, you may wish to repeat the adjustment.

Frequency Accuracy Adjustment

In this procedure the frequency accuracy of the analyzer's source is set by adjusting the 10 MHz internal reference clock.

Required Equipment

Equipment Description	Recommended Model or Part Number	
	50Ω (standard)	75Ω (opt. 1EC)
Frequency counter	HP 5342A	HP 5342A
BNC cable	8120-1839	8120-1839
Minimum loss pad	N/A	HP 11852B
Adapter, type-N(m) to BNC(f)	1250-0780	1250-0780

Estimated Adjustment Time

This adjustment takes approximately five minutes to perform.

Procedure

1. Connect the equipment as shown in Figure 2-6.

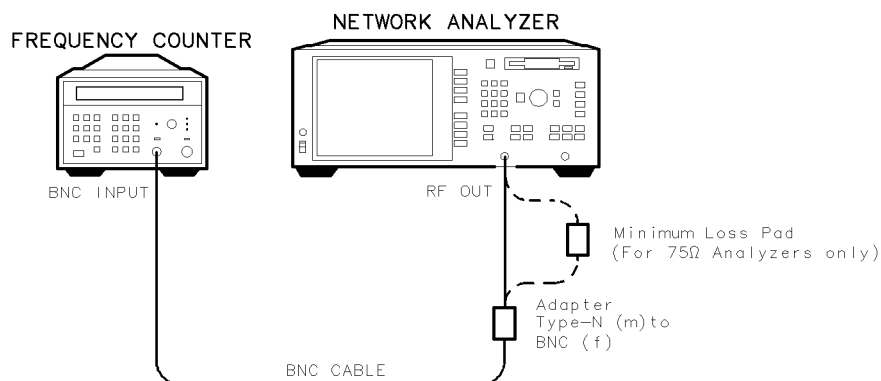

sd69b

Figure 2-6. Setup for Frequency Accuracy Adjustment

2. Set the frequency counter input switches to the "10 Hz - 500 MHz" and 50Ω positions.
3. On the analyzer, press **[PRESET]** **[FREQ]** **[CW]** **[500]** **[MHz]** **[MENU]** (in the SOURCE keypad section) **[Trigger]** **[Hold]**. If the frequency counter reading is 500 MHz ±2500 Hz, you do not need to make this adjustment. However, you can still make this adjustment to improve the frequency accuracy.
4. To proceed with the adjustment, disconnect the frequency counter and adapter(s) from the RF OUTPUT connector.

5. Remove the handles and front panel by following these steps and referring to Figure 2-7.
 - a. Remove the trim strip from the handles.
 - b. Remove the screws attaching each handle to the analyzer.
 - c. Pull the analyzer toward you until it extends about two inches over the edge of the table top.
 - d. Grasp and pull the front panel with two hands: one on the top-middle of the panel, and the other on the bottom-middle of the panel.

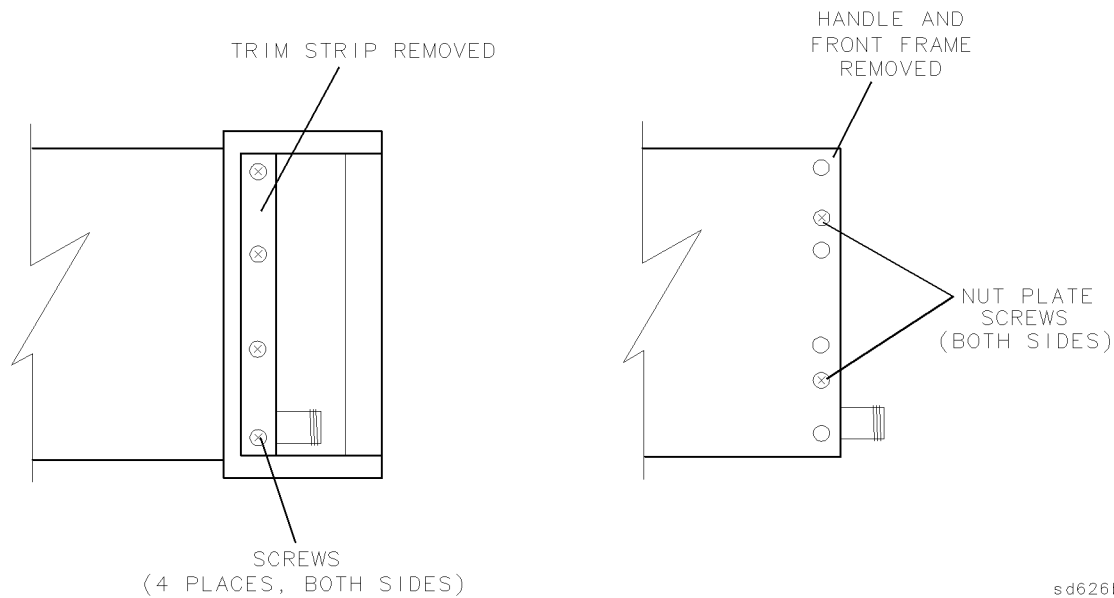

Figure 2-7. Removing the Handles and Front Panel

6. Reconnect the frequency counter and adapter(s) to the RF OUTPUT connector.
7. To obtain a counter reading of 500 MHz \pm 2500 Hz or better, adjust R1 on the A3 fractional-N/reference assembly (accessible through a hole in shield between J1 and J3).
8. Reassemble the analyzer.

Set Serial Number, Adjustment #100

This procedure shows you how to store the analyzer's serial number in the CPU bootROM. While this is not normally required, you may have to perform this procedure when you replace the CPU board.

You can only perform this procedure over HP-IB, so an HP BASIC controller (either external or IBASIC) is required. The performance test software (HP part number 08712-10011) can also be used to store the analyzer's serial number.

Note Where XXXXXXXXXXXX appears throughout this procedure, replace those characters with the serial number of your analyzer but maintain the leading and following apostrophes (both are ASCII character 39). For example, if the serial number of your analyzer is US34405555, the HP BASIC line of code would be:

```
OUTPUT 716;"DIAG:SNUM 'US34405555'"
```

IMPORTANT: Make sure there is a space between SNUM and the first apostrophe.

Required Equipment

A computer with HP-IB capabilities is required. If IBASIC (option 1C2) is installed, an IBM PC-AT style keyboard is the only requirement.

Estimated Adjustment Time

This adjustment takes approximately two minutes to perform.

Procedure

1. Write down the 10-character serial number, exactly as shown on the analyzer rear-panel label.
2. Use one of the following BASIC commands to set the serial number: (Replace the XXXXXXXXXXXX in the command with your analyzer's serial number.)

- a. If you are using HP BASIC from an external controller, enter:

```
OUTPUT 716;"DIAG:SNUM 'XXXXXXXXXX'"
```

then press **ENTER**.

On the analyzer, press **Return to Local**.

This assumes that the analyzer is at address 16 and the HP-IB is at 7. If not, either use the analyzer's actual address, or change the analyzer's address to 16.

- b. If you are using IBASIC:

With an external keyboard connected, press **ESC** to view the IBASIC command line. Then type the following:

```
OUTPUT 800;"DIAG:SNUM 'XXXXXXXXXX'"
```

and press **ENTER**.

- c. Press **SYSTEM OPTIONS** **Service Instrument Info** to verify that you correctly installed the serial number. The serial number is displayed in the dialogue box.

In Case of Difficulty

If the analyzer displays an error message that tells you the serial number has the wrong format, check the rear-panel serial number tag again and verify that you have the correct serial number.

If the analyzer displays an error message that tells you “Serial number already set,” that means a serial number is already installed on that CPU board and therefore cannot be changed. Contact your nearest HP Sales and Service Office for instructions.

LO Power Correction, Adjustment #101

Note This adjustment is only required for the HP 8711B and HP 8712B. It is *not* required for the HP 8713B and HP 8714B.

This procedure adjusts the DAC that controls the LO power level for optimal mixer performance.

Required Equipment

Equipment Description	Recommended Model or Part Number	
	50 Ω (standard)	75 Ω (opt. IEC)
Type-N cable	8120-4781	8120-2408

Estimated Adjustment Time

This adjustment takes approximately one minute to perform.

Procedure

1. Connect a cable from the RF OUT port to the RF IN port.
2. Press **PRESET** **SYSTEM OPTIONS** **Service Test and Adjustments** **Select Adjustment** **101** **ENTER** **Execute Test**.

This is a fully automated adjustment handled by the internal firmware. Follow the instructions displayed on the analyzer's CRT.

3. If you are *not* going to make any more adjustments, finish with the procedure titled "To Permanently Store CCs in the Analyzer," part of "Storing and Recalling Correction Constants" in Chapter 8.

If you *are* going to make more adjustments, save the correction constant data that you have generated so far. Insert a formatted disk into the internal disk drive. Press **SYSTEM OPTIONS** **Service Update Corr Const** **Store CC to Disk**. This creates a file (or writes over an existing file) where the correction constants are stored.

Switched Gain Correction, Adjustment #102

In this procedure, the analyzer sets the gain for each analyzer input. The analyzer can apply different gains to the R, A, and B input signals to make sure that the signal is in the correct range for proper ADC (analog to digital converter) operation.

Required Equipment

Equipment Description	Recommended Model or Part Number	
	50 Ω (standard)	75 Ω (opt. 1EC)
Type-N cable	8120-4781	8120-2408
20 dB attenuator ¹	HP 8491A Opt 020	0955-0768
Voltage reference source ¹ (p/o service kit)	08712-60031	08712-60031

¹ These items may not be required; see text below.

The required equipment for this adjustment varies depending upon whether or not the analyzer has an attenuator installed (Option 1E1). If the analyzer has an internal attenuator, then only a type-N cable is needed to complete the adjustment. If an attenuator is not installed, then a 20 dB attenuator of the proper impedance will also be required, as well as the voltage reference source (contained in the service kit).

If a 75 Ω 20 dB attenuator is not readily available for option 1EC analyzers, you can substitute two back-to-back minimum loss pads with a 6 dB 50 Ω attenuator inserted in between (several adapters may also be required). A 10 dB 50 Ω attenuator may also be used instead of the 6 dB attenuator.

If the voltage reference source is not available, any stable dual ± 24 mV voltage source will work. This source voltage is not critical; any value between 20mV and 30mV should suffice. See adjustment #103, next, for connection information.

Estimated Adjustment Time

This adjustment takes approximately two minutes to perform.

Procedure

1. Press **(PRESET)** **(SYSTEM OPTIONS)** **Service Test and Adjustments** **Select Adjustment** **(102)** **(ENTER)** **Execute Test**.
2. This is a fully automated adjustment handled by the internal firmware. Follow the instructions on the analyzer's display.
The analyzer presets after the test is done.
3. If you are *not* going to make any more adjustments, finish with the procedure titled "To Permanently Store CCs in the Analyzer" in the "Correction Constants and Firmware" chapter of this guide.

If you *are* going to make more adjustments, save the correction constant data that you have generated so far. Insert a formatted disk into the internal disk drive. Press **(SYSTEM OPTIONS)** **Service Update Corr Const Store CC To Disk**. This creates a file (or writes over an existing file) where the correction constants are stored.

External Detector Correction, Adjustment #103

This procedure shows you how to generate correction constants for the receiver to make external detector or internal broadband measurements. Perform this test whether or not you plan to use external detectors.

In this test, an accurate ± 0.5 V is provided to both the X and Y detector inputs.

Required Equipment

Equipment Description	Recommended Model or Part Number
Voltage reference source ¹ (part of service kit)	08712-60031

¹ See Note below.

Note If a voltage reference source is not available, connect the requested voltages to the external detector connector as shown in Figure 2-8. Note that both a positive and negative voltage are required simultaneously, and both must be referenced to ground.

pin D = V+

pin C = V-

pin K = GND

These voltages may be obtained from a dual power supply, however it is possible to derive the required voltages from the external detector connector itself.

pin B = -15V with respect to GND (pin K)

pin A = +15 with respect to GND (pin K)

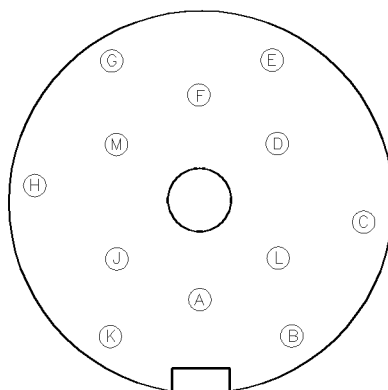

sd623b

Figure 2-8. External Detector Connector, Front View

Estimated Adjustment Time

This adjustment takes approximately two minutes to perform.

Procedure

1. Press **(PRESET)** **(SYSTEM OPTIONS)** **Service** **Test and Adjustments** **Select Adjustment** **(103)** **(ENTER)** **Execute Test**.

2. This is a fully automated adjustment handled by the internal firmware. Follow the instructions on the analyzer's display.

If the analyzer fails the adjustment test, resulting in a warning message, check the connections, voltages, and switch positions, then rerun the test.

3. If you are *not* going to make any more adjustments, finish with the procedure titled "To Permanently Store CCs in the Analyzer," part of "Storing and Recalling Correction Constants" in Chapter 8.

If you *are* going to make more adjustments, save the correction constant data that you have generated so far. Insert a formatted disk into the internal disk drive. Press **(SYSTEM OPTIONS)** **Service** **Update Corr Const** **Store CC To Disk**. This creates a file (or writes over an existing file) where the correction constants are stored.

Auxiliary Input Correction, Adjustment #111

This procedure shows you how to generate correction constants for the auxiliary input. The procedure measures two voltages (0 and +10.000 volts) applied to the auxiliary input to compute the offset and gain of the auxiliary input circuitry.

Required Equipment

Equipment Description	Recommended Model or Part Number
Voltage reference source (part of service kit)	08712-60031 or any +10.000 voltage source.
50Ω BNC cable	any

Estimated Adjustment Time

This adjustment takes approximately one minute to perform.

Procedure

1. Press **PRESET** **SYSTEM OPTIONS** **Service Test and Adjustments** **Select Adjustment** **111** **ENTER** **Execute Test**.
2. This is a fully automated adjustment handled by the internal firmware. Follow the instructions on the analyzer's display.
3. If you are *not* going to make any more adjustments, finish with the procedure titled "To Permanently Store CCs in the Analyzer," part of "Storing and Recalling Correction Constants" in Chapter 8.

If you *are* going to make more adjustments, save the correction constant data that you have generated so far: insert a formatted disk into the internal disk drive. Press **SYSTEM OPTIONS** **Service Update Corr Const** **Store CC To Disk**. This creates a file (or writes over an existing file) where the correction constants are stored.

Source Power (ALC) Correction, Adjustment #104

In this procedure, the analyzer creates a table of values that corrects the source output power over different frequencies and power levels. The analyzer reads values from a power meter to determine the actual source output level. An HP 437B or HP 438A (with firmware revision 3.0 or greater) power meter is required for this test. Other power meters will not be controlled correctly by the analyzer.

Note If your analyzer has a step attenuator installed (option 1E1), you need an HP 8481D power sensor to perform this adjustment procedure.

Note If your analyzer has firmware revision B.03.00 and does not have an optional attenuator (option 1E1), then you must update the firmware to revision 3.01 or greater.

Required Equipment

Equipment Description	Recommended Model or Part Number	
	50Ω (standard)	75Ω (opt.1EC)
Power meter	HP 437B/438A	HP 437B/438A
Power sensor	HP 8482A	HP 8482A
High sensitivity power sensor (for opt. 1E1 analyzers only)	HP 8481D	HP 8481D
10 dB attenuator*	HP 8491A opt 010	N/A
Minimum loss pad	N/A	HP 11852B
HP-IB cable	HP 10833A	HP 10833A

*The HP 8713B and HP 8714B may not require an attenuator for this adjustment.

Estimated Adjustment Time

This adjustment takes approximately five to ten minutes to run, depending on the installed options.

Procedure

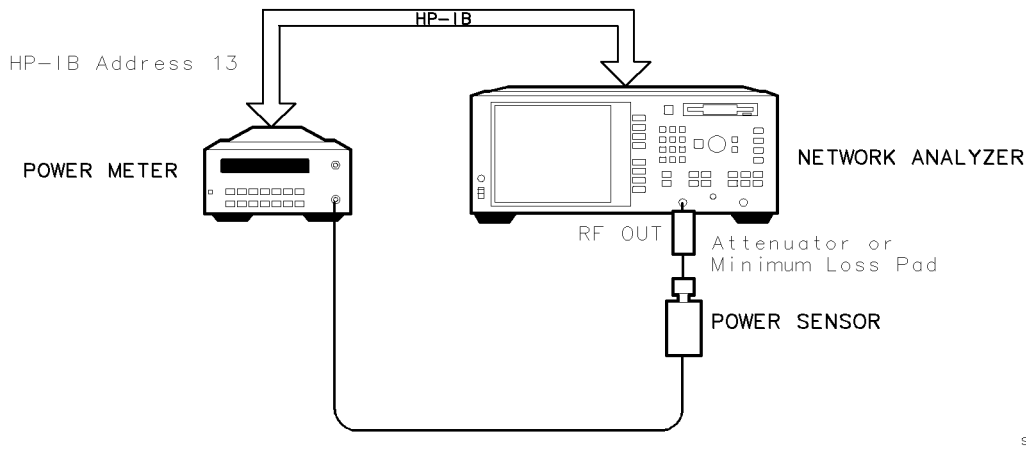

Figure 2-9. Setup for Source Power Correction

Note Before you begin this adjustment, you should store a copy of the correction constants in a disk file for later retrieval, if you have not done so already. Refer to the procedure in “Storing and Recalling Correction Constants.”

1. Switch ON the power meter and let it warm up for at least five minutes.
2. Connect an HP-IB cable between the analyzer and the power meter. Set the HP-IB address of the power meter to 13. Disconnect any controller that may be on the HP-IB bus.
3. Press **PRESET** **SYSTEM OPTIONS** **Service** **Test and Adjustments** **Select Adjustment** **104** **ENTER** **Execute Test** .
4. Follow the instructions on the screen.
5. When the test is done, disconnect the power sensor and press **PRESET** **SYSTEM OPTIONS** **HP-IB Talker/Listener** .
6. If you are *not* going to make any more adjustments continue with the procedure titled “To Permanently Store CCs in the Analyzer,” part of “Storing and Recalling Correction Constants” in Chapter 8.

If you *are* going to make more adjustments, save the correction constant data that you have generated so far. Insert a formatted disk into the internal disk drive. Press **SYSTEM OPTIONS** **Service** **Update Corr Const** **Store CC To Disk** . This creates a file (or writes over an existing file) where the correction constants are stored.

In Case of Difficulty

If the system locks up or the power meter does not respond to the analyzer, make sure the HP-IB cable is correctly connected and the HP-IB address on the power meter is set to 13.

If a “log error” occurs on the power meter during the low power adjustment and the test stops, you will need to do the test again. Switch OFF the analyzer and preset the power meter.

If the power meter over-ranges repeatedly during this adjustment, see the note regarding firmware revision B.03.00 on the previous page.

Note

If you must cycle the analyzer's line power, and you did not store the correction constants to disk before starting this adjustment, you need to repeat all of the adjustments done up to this point, then repeat the source power correction. If you did save the correction constants to disk, recall the correction constants data from disk (as described in "Storing and Recalling Correction Constants"), then go back to step 1 to repeat this adjustment.

B Amplitude Correction, Adjustment #105

This procedure corrects the B narrowband input so that it displays a flat 0 dB trace with an input of 0 dBm from the analyzer's internal source.

Required Equipment

Equipment Description	Recommended Model or Part Number	
	50Ω (standard)	75Ω (opt. IEC)
Type-N cable	8120-4781	8120-2408

Estimated Adjustment Time

This adjustment takes approximately one minute to perform.

Procedure

1. Connect a cable from the RF OUT port to the RF IN port.
2. Press **PRESET** **SYSTEM OPTIONS** **Service Test and Adjustments** **Select Adjustment** **105** **ENTER** **Execute Test**.
3. Follow the instructions on the screen.
4. If you are *not* going to make any more adjustments continue with procedure titled "To Permanently Store CCs in the Analyzer," part of "Storing and Recalling Correction Constants" in Chapter 8.

If you *are* going to make adjustments, save the correction constant data that you have generated so far: insert a formatted disk into the internal disk drive. Press **SYSTEM OPTIONS** **Service Update Corr Const** **Store CC To Disk**. This creates a file (or writes over an existing file) where the correction constants are stored.

Transmission (B/R) Correction, Adjustment #106

This procedure performs a transmission response calibration to correct for frequency response in narrowband B/R measurements. It is recommended that you use a short-length, high quality cable to perform this adjustment.

Required Equipment

Equipment Description	Recommended Model or Part Number	
	50 Ω (standard)	75 Ω (opt. IEC)
Type-N cable	8120-4781	8120-2408

Estimated Adjustment Time

This adjustment takes approximately one minute to perform.

Procedure

1. Connect a cable from the RF OUT port to the RF IN port.
2. Press **PRESET** **SYSTEM OPTIONS** **Service Test and Adjustments** **Select Adjustment** **106** **ENTER** **Execute Test**.
3. Follow the instructions on the screen.
4. If you are *not* going to make any more adjustments, finish with the procedure titled “To Permanently Store CCs in the Analyzer,” part of “Storing and Recalling Correction Constants” in Chapter 8.

If you *are* going to make adjustments, save the correction constant data that you have generated so far: insert a formatted disk into the internal disk drive. Press **SYSTEM OPTIONS** **Service Update Corr Const Store CC To Disk**. This creates a file (or writes over an existing file) where the correction constants are stored.

AM Delay Correction, Adjustment #112

This procedure compensates for any loss in the analyzer's AM delay circuitry.

Note This adjustment is only required for analyzers with option 1DA or option 1DB.

Required Equipment

Equipment Description	Recommended Model or Part Number	
	50 Ω (standard)	75 Ω (opt. 1EC)
Type-N cable	8120-4781	8120-2408

Estimated Adjustment Time

This adjustment takes approximately one minute to perform.

Procedure

1. Connect a through cable between the RF IN port and the RF OUT port.
2. Press **PRESET** **SYSTEM OPTIONS** **Service Test and Adjustments** **Select Adjustment** **112** **ENTER** **Execute Test**.
3. Follow the instructions on the screen.
4. If you are *not* going to make any more adjustments, finish with the procedure titled "To Permanently Store CCs in the Analyzer," part of "Storing and Recalling Correction Constants" in Chapter 8.

If you *are* going to make more adjustments, save the correction constant data that you have generated so far. Insert a formatted disk into the internal disk drive. Press **SYSTEM OPTIONS** **Service Update Corr Const** **Store CC To Disk**. This creates a file (or writes over an existing file) where the correction constants are stored.

Reflection (One-Port) Correction, Adjustment #107

This procedure corrects for errors in reflection measurements. The analyzer measures an open, a short, and a load to perform a one-port reflection calibration.

Required Equipment

Equipment Description	Recommended Model or Part Number	
	50 Ω (standard)	75 Ω (opt. IEC)
Calibration kit	HP 85032B/E	HP 85036B/E

Estimated Adjustment Time

This adjustment takes approximately three minutes to perform.

Procedure

1. Press **(PRESET)** **(SYSTEM OPTIONS)** **Service Test and Adjustments** **Select Adjustment** **(107)** **(ENTER)** **Execute Test**.
2. Follow the instructions on the screen.
3. If you are *not* going to make any more adjustments, finish with the procedure titled "To Permanently Store CCs in the Analyzer," part of "Storing and Recalling Correction Constants" in Chapter 8.

If you *are* going to make more adjustments, save the correction constant data that you have generated so far. Insert a formatted disk into the internal disk drive. Press **(SYSTEM OPTIONS)** **Service Update Corr Const** **Store CC To Disk**. This creates a file (or writes over an existing file) where the correction constants are stored.

R* Amplitude Correction, Adjustment #108

This procedure generates correction constants to improve absolute power accuracy in R* measurements. (Frequency effects are corrected in “R* Frequency Response Correction, Adjustment #109.”)

Required Equipment

Equipment Description	Recommended Model or Part Number	
	50Ω (standard)	75Ω (opt. IEC)
Type-N (m) termination (p/o HP 85032B/E or HP 85036B/E)	00909-60009	00909-60019

Caution You must perform adjustment #103 (external detector correction) and adjustment #104 (source power correction) before running the R* amplitude correction adjustment.

Estimated Adjustment Time

This adjustment takes approximately two minutes to perform.

Procedure

1. Connect a termination (included in the HP 85032B/E or 85036B/E calibration kit) to the RF OUT port.
2. Press **PRESET** **SYSTEM OPTIONS** **Service Test and Adjustments** **Select Adjustment** **108** **ENTER** **Execute Test**.

3. Follow the instructions on the screen.

If the analyzer displays an error message and aborts the adjustment, the calibration data from adjustments #103 and #104 are probably corrupt and adjustments #103 and #104 should be performed again.

4. If you are *not* going to make any more adjustments, finish with the procedure titled “To Permanently Store CCs in the Analyzer,” part of “Storing and Recalling Correction Constants” in Chapter 8.

If you *are* going to make more adjustments, save the correction constant data that you have generated so far. Insert a formatted disk into the internal disk drive. Press **SYSTEM OPTIONS** **Service Update Corr Const** **Store CC To Disk**. This creates a file (or writes over an existing file) where the correction constants are stored.

R* Frequency Response Correction, Adjustment #109

This procedure corrects for frequency response errors in R* measurements.

Caution You must perform adjustment #108 (R* amplitude correction) before running the R* frequency response correction adjustment.

Required Equipment

Equipment Description	Recommended Model or Part Number	
	50Ω (standard)	75Ω (opt.1EC)
Type-N (m) termination (p/o HP 85032B/E or HP 85036B/E)	00909-60009	00909-60019

Estimated Adjustment Time

This adjustment takes approximately one minute to perform.

Procedure

1. Connect a termination (included in the HP 85032B/E or HP 85036B/E calibration kit) to the RF OUT port.
2. Press **(PRESET)** **(SYSTEM OPTIONS)** **Service** **Test and Adjustments** **Select Adjustment** **(109)** **(ENTER)** **Execute Test**.
3. Follow the instructions on the screen.
4. If you are *not* going to make any more adjustments, finish with the procedure titled “To Permanently Store CCs in the Analyzer,” part of “Storing and Recalling Correction Constants” in Chapter 8.

If you *are* going to make more adjustments, save the correction constant data that you have generated so far. Insert a formatted disk into the internal disk drive. Press **(SYSTEM OPTIONS)** **Service** **Update Corr Const** **Store CC To Disk**. This creates a file (or writes over an existing file) where the correction constants are stored.

B* Amplitude Correction, Adjustment #110

This adjustment requires a controller to set the proper power levels and then signal the analyzer that the proper levels have been set. There are two ways to perform this adjustment:

1. Use the automated performance test program described in “Instructions for the Network Analyzer Performance Test Software” in Chapter 1. This program has a selection for performing this adjustment labeled “ADJUSTMENT B* AMPLITUDE.” The configuration and equipment required are shown in Figures 2-10 and 2-11. Refer to the following section titled “Running B* Adjustment Correction Using the Performance Test Software (08712-10011).”
2. If your analyzer has option 1C2 (IBASIC) or if you have any HP 8711A, HP 8711B, HP 8712B, HP 8713B, or HP 8714B available with this option, the *IBASIC Example Programs Disk* (HP P/N 08712-10003) contains a program that will automate this adjustment without any external controller. Refer to “Running B* Adjustment from IBASIC,” later in this section.

Caution You must perform adjustment #103 (external detector correction) before running the B* amplitude correction adjustment.

Running the B* Amplitude Correction Using the Performance Test Software (08712-10011)

This adjustment sets up a 30 MHz signal and applies power levels of -30 dBm to $+18$ dBm (in 2 dB steps) to the B* input. The analyzer then compares the measured value to the nominal value and generates a correction table. To perform this procedure you need an HP BASIC controller. The controller uses the power meter to accurately set the level of an external source. The program then applies this signal to the analyzer, and then informs the analyzer when the level is correct. This external source level is then measured by the B* input.

Required Equipment

Equipment Description	Recommended Model or Part Number	
	50 Ω (standard)	75 Ω (opt. IEC)
HP BASIC controller with BASIC 5.0 or higher or option 1C2	HP 9000 series 200/300 computer	HP 9000 series 200/300 computer
Test software	08712-10011	08712-10011
Function generator	HP 8116A	HP 8116A
Power meter	HP 437B or 438A	HP 437B or 438A
Power sensor	HP 8482A	HP 8482A
Minimum loss pad	N/A	HP 11852B
6 dB attenuator	HP 8491 option 006	N/A
10 dB step attenuator	HP 8496A/G	HP 8496A/G
Attenuator/switch driver (optional)	HP 11713A	HP 11713A
HP-IB cables (4 or 5)	HP 10833A	HP 10833A
Type-N cable (2)	8120-4781	8120-4781
Adapter, BNC(m) to N(f)	1250-0077	1250-0077

Estimated Adjustment Time

This adjustment takes approximately five to ten minutes to perform.

Procedure

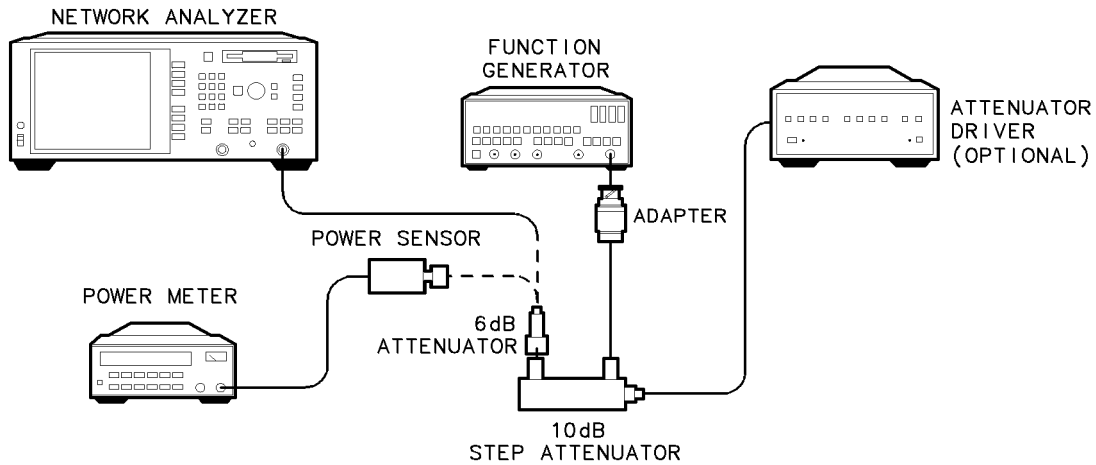

sd610b

Figure 2-10. Setup for B* Amplitude Correction for 50Ω Analyzers

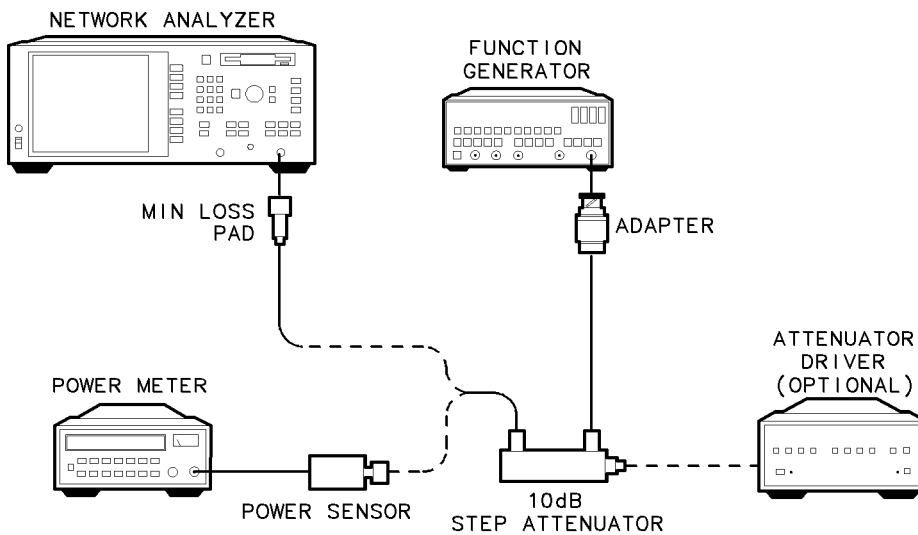

sd611b

Figure 2-11. Setup for B* Amplitude Correction for 75Ω Analyzers

1. This is a fully automated adjustment handled by the internal firmware. Refer to the “Performance Tests” chapter for information on loading and running the software. In the Test Selection Menu, select ADJUSTMENT B* AMPLITUDE.
2. Follow the prompts to complete the adjustment. Refer to Figure 2-10 or Figure 2-11.

Caution IMPORTANT: When the test has completed, store the correction constants to disk. The program *does not* automatically save them.

3. If you are *not* going to make any more adjustments, finish with the procedure titled “To Permanently Store CCs in the Analyzer,” part of “Storing and Recalling Correction Constants” in Chapter 8.

If you *are* going to make more adjustments, save the correction constant data that you have generated so far. Insert a formatted disk into the internal disk drive. Press **SYSTEM OPTIONS** **Service Update Corr Const Store CC To Disk**. This creates a file (or writes over an existing file) where the correction constants are stored.

Running B* Amplitude Correction Adjustment #110 from IBASIC

Located on the *IBASIC Example Programs Disk* (HP part number 08712-10003) is a program called "ADJ_110." This program will also automate the B* amplitude correction adjustment. No other controller is necessary if IBASIC (option 1C2) is installed in your analyzer.

Note If the analyzer you are adjusting does not have the IBASIC option installed (option 1C2), you can run this adjustment from another Option 1C2 HP 8711A/11B/12B/13B/14B network analyzer.

The following list of equipment is required to run this program. However, if your analyzer is a 50Ω unit with sufficient power from its internal source, it may be possible to eliminate the external HP 8116A source. If the capabilities exist, the 6 dB pad will also not be required.

Note Not all analyzers may be capable of the required high power (>+18.3 dBm at 30 MHz). If this mode of operation is selected, the program will check for this power capability before proceeding.

The connection diagram is similar to that shown in Figures 2-10 and 2-11.

Required Equipment

Equipment Description	Recommended Model or Part Number	
	50Ω (standard)	75Ω (opt. IEC)
Function generator	HP 8116A	HP 8116A
Power meter	HP 437B or 438A	HP 437B or 438A
Power sensor	HP 8482A	HP 8482A
Minimum loss pad	N/A	HP 11852B
Attenuator 6 dB	HP 8491A option 006	N/A
Step attenuator	HP 8496A/G	HP 8496A/G
Attenuator/switch driver (optional)	HP 11713A	HP 11713A
HP-IB cables (3 or 4)	HP 10833A	HP 10833A
Type-N cable (2)	8120-4781	8120-4781
Adapter, BNC(m) to N(f)	1250-0077	1250-0077

Estimated Adjustment Time

This adjustment takes approximately five to ten minutes to perform.

Procedure

1. Switch ON all equipment and allow to warm up at least 1/2 hour.
2. Connect all devices together via HP-IB, preferably using the default addresses. Make sure no other controller is connected.
3. Insert the *IBASIC Example Programs Disk* (HP part number 08712-10003) into the disk drive of your option 1C2 analyzer and press **SAVE RECALL** **Select Disk** **Internal 3.5" Disk**.
4. Select the program **ADJ_110** and press **Programs** **Recall Program**. When recall is complete press **Run**.
5. The program will ask you if you are using this analyzer as a controller for another analyzer that does not contain IBASIC. If you *are*, answer "YES."

If you are *not* using this analyzer as a controller for another analyzer, answer "NO."

Answer accordingly, then select the **CONFIG** softkey.

6. At this point you can configure the program according to your equipment requirements. Use the **↑** and **↓** keys to point to a selection the press **SELECT** or **ENTER**. The selected item can then be changed, or in some cases the selection will simply toggle to the opposite choice. Descriptions of the menu selections follow:

Analyzer Address :	The HP-IB address of the analyzer you will be controlling (usually 16). This value doesn't matter if you are not controlling another analyzer. If selected, you will be asked to enter the desired two-digit address. Use care, there is little error checking on any data entry. Note that if one analyzer is controlling another analyzer, both of them cannot be at the same address.
Power Meter Address :	The two-digit HP-IB address, default is 13.
Atten Driver Address :	As above, if this device is not used, the address is irrelevant. Default 28.
Function Generator Address :	As above, if this device is not used, the address is irrelevant. Default 14.
Power Sensor Cal Factor :	Enter the 50 MHz reference cal factor in percent (typically about 99-100%) Note that this program assumes the same value for the 30 MHz cal factor. Any actual difference is negligible.
Function Generator Used :	Default is HP 8116A. If selected, the value toggles to 'NONE.' This selection will use the analyzer's internal source instead. Note you must use an HP 8116A when testing a 75Ω analyzer.

Atten/Sw Driver Used:

Default is HP 11713A. If selected, the value toggles to 'NONE.' This will allow manual setting of the 10 dB step attenuator, which is required if you are using a manual 10 dB step attenuator such as the HP 8495A, HP 8496A or HP 355D.

Attenuator 40 dB section:

This is only applicable for the HP 8496G automated step attenuator. Since this attenuator has two 40 dB sections, you must select which section is to be used. Default is section 3 (i.e. that section which is engaged when switch #3 of the HP 11713A is lit). Only if you have cal data for section #4 of the attenuator, should this value be changed. If in doubt, measure each section to see which section you have data for. This data will be input below.

10, 20, 30, 40 dB section value:

Select these to enter the actual 30 MHz insertion loss of each section of your attenuator. All values are referenced to the 0 dB position of the attenuator. Use care when entering the 40 dB section value; see above. Generally, the 30 dB value will be the sum of the 10 and 20 dB sections.

7. When done entering the values, press **DONE**. The values are maintained even if the program is halted and then re-run. When all the equipment has been connected, switched ON, and has had the addresses set, press **RESUME** to begin the adjustment.

The program will search for each HP-IB device. If any device is not found, an error is reported. You will be asked to zero and calibrate the power sensor.

8. If the internal analyzer source was selected, the program will test the 30 MHz output power capability for at least +18.3 dBm. If this is not obtainable, the program will halt; you must then use an HP 8116A.
9. Follow the instructions on the display. No connection diagram is provided; refer to Figure 2-10 or Figure 2-11 if needed. The 6 dB pad is not used if the HP 8116A is not used as the source. The test is divided into two parts. First the power meter reads the power from the source, adjusting the levels as required. When all the needed levels have been measured, disconnect the sensor and connect the RF output to the RF input of the analyzer under test. The previously measured levels are set again, and the analyzer uses these levels to generate correction constants. This adjustment takes about 10 minutes to complete.

Caution **IMPORTANT:** When you are finished, save the correction constants to disk. The program *does not* automatically save them.

10. If you are *not* going to make any more adjustments, finish with the procedure titled "To Permanently Store CCs in the Analyzer," part of "Storing and Recalling Correction Constants" in Chapter 8.

If you *are* going to make more adjustments, save the correction constant data that you have generated so far. Insert a formatted disk into the internal disk drive. Press **(SYSTEM OPTIONS) Service Update Corr Const Store CC To Disk**. This creates a file (or writes over an existing file) where the correction constants are stored.

Assembly Replacement

Introduction

This chapter describes how to disassemble and reassemble your network analyzer for the purpose of replacing a failed assembly. It also contains specific instructions for repairing or replacing each assembly.

Warning **Parts of this instrument have sharp edges. Work carefully to avoid injury.**

Required Tools

- TORX drivers, sizes 10 and 15
- 5/8-inch wrench (for BNC nuts)
- 5/16-inch wrench (preferably the modified wrench included in the service kit)
- 5/16-inch nut driver (required only for display replacement)

Major Assembly Removal/Replacement

The following sections describe how to remove your analyzer's major assemblies. These include the:

- A1 front panel assembly
- A2 CPU assembly
- A3 fractional-N/reference assembly
- A4 source assembly
- A5 receiver assembly
- A6 power supply assembly
- A7 CRT assembly
- A8 floppy disk drive assembly (attached to the A2 CPU assembly)
- Option 1EC attenuator assembly
- Option 1DA/1DB AM delay assembly

Note All assembly procedures can be described as the removal procedures performed in reverse order.

For your convenience, brief disassembly instructions are located on a label on the bottom of the analyzer.

A1 Front Panel Assembly Replacement

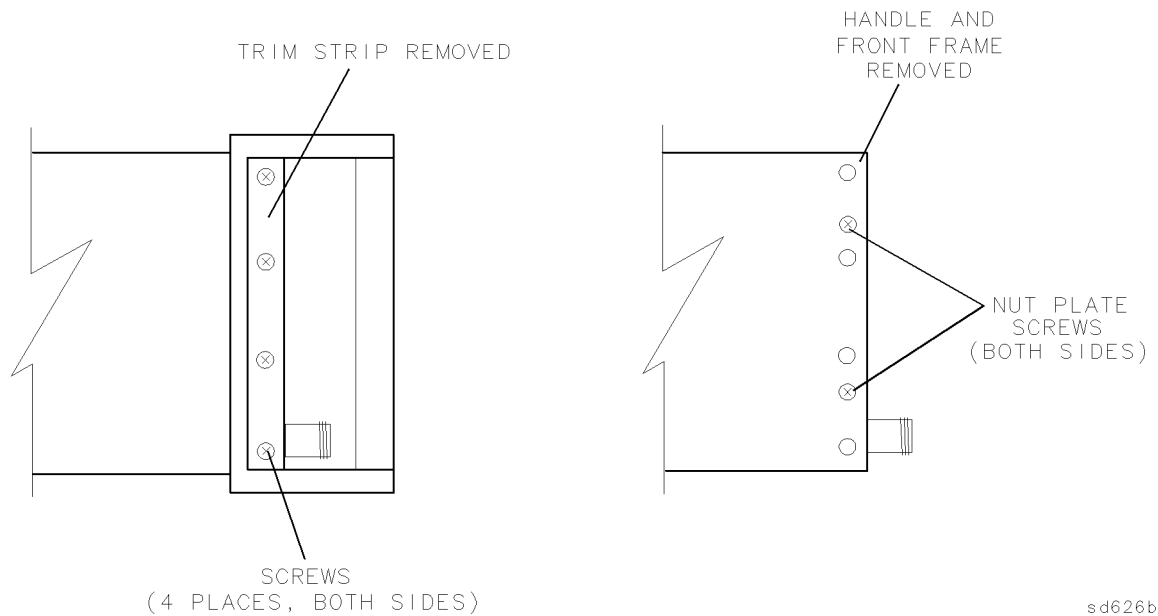

Figure 3-1. Removing the Handles and Front Panel Assembly

The A1 assembly comes in two different versions: 50 Ω and 75 Ω . However, the difference is only cosmetic. Both assemblies include all front panel components including frame, keyboard, keypad, and knob. The assembly does not include the model number nameplate, which must be ordered separately, nor does it include the type-N connectors which are part of the A5 receiver assembly.

If the front frame has been damaged, but the keypad and knob are OK, you can save money by ordering only the following three parts:

- Front frame
- Nameplate (choose according to model number)
- Front dress panel (choose 50 Ω or 75 Ω version)

How to Remove the Front Panel Assembly

1. Disconnect the power cord.
2. Remove the front handles (trim strip first). See Figure 3-1.
3. Pull the center top of the front panel up slightly and pull the center bottom down slightly to release the two centered catches.
4. Pull the front panel away from the cabinet several inches.
5. Disconnect the ribbon cable from the circuit board. If you will need to remove the A3, A4, or A5 assemblies later, remove the handle nut plate on the right side.

If you are planning to remove the A6 or A7 assembly, you should also remove the handle nut plate on the left side.

6. To remove the RPG knob, pull it off its splined shaft.

7. To remove the RPG, disconnect the five-wire cable from A1J2. Remove the knob, hex nut, and washer.

Note If you are replacing a probe power fuse, they are located in sockets on the A1 front panel assembly. See Table 7-3, Item 7.

A2 CPU Board Assembly Replacement

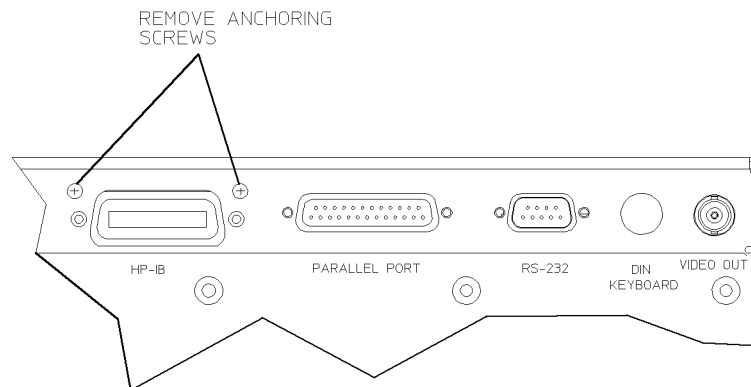

sd646b

Figure 3-2. Removing the CPU Assembly

Caution Please read the following carefully.

Failure to follow instructions may result in an improperly operating analyzer. Make a copy of the correction constants (see Chapter 8) before replacing the A2 CPU assembly.

Also, it is recommended that your analyzer's firmware disk be available before replacing the A2 CPU assembly. The replacement A2 CPU assembly may be shipped from the factory with a different firmware revision than your current firmware revision. If the replacement A2 CPU assembly was shipped with a different firmware revision, but the original firmware revision is desired, you can restore the original firmware from the analyzer's firmware disk. See "Upgrading Firmware" in Chapter 8.

Caution Perform the following *only* at an approved ESD workstation. See Figure 4-1 in the "Troubleshooting and Block Diagrams" chapter.

Any A2 CPU replacement assembly is supplied in its minimal format. This may not work in all instances depending upon model and options unless the following instructions are adhered to. The latest-version firmware will have already been installed at the factory. If you wish to change this firmware you will need a firmware disk containing the version desired.

How to Remove the CPU Board Assembly

Perform all of the required steps listed below, if applicable:

1. Disconnect the power cord.
2. Disconnect all cables from the top row of connectors on the rear panel. Next, refer to Figure 3-2 and remove the two anchoring screws just above the HP-IB connector.
3. Remove the front panel assembly (see "How to Remove the Front Panel Assembly"). Remove both the left and right handle nut plates.
4. Remove the display assembly (see "How to Remove the Display Assembly").
5. Withdraw the CPU assembly from its cavity.

6. Exchange bootROMs (This should be done on all units and *must* be done on any HP 8712B/14B).
 - a. Locate bootROM U82. See Figure 3-3.
 - b. Carefully remove the bootROMs from both boards and insert the original bootROM into the replacement CPU board, making sure that it is properly oriented.
 - c. Now insert the remaining bootROM into the old assembly.

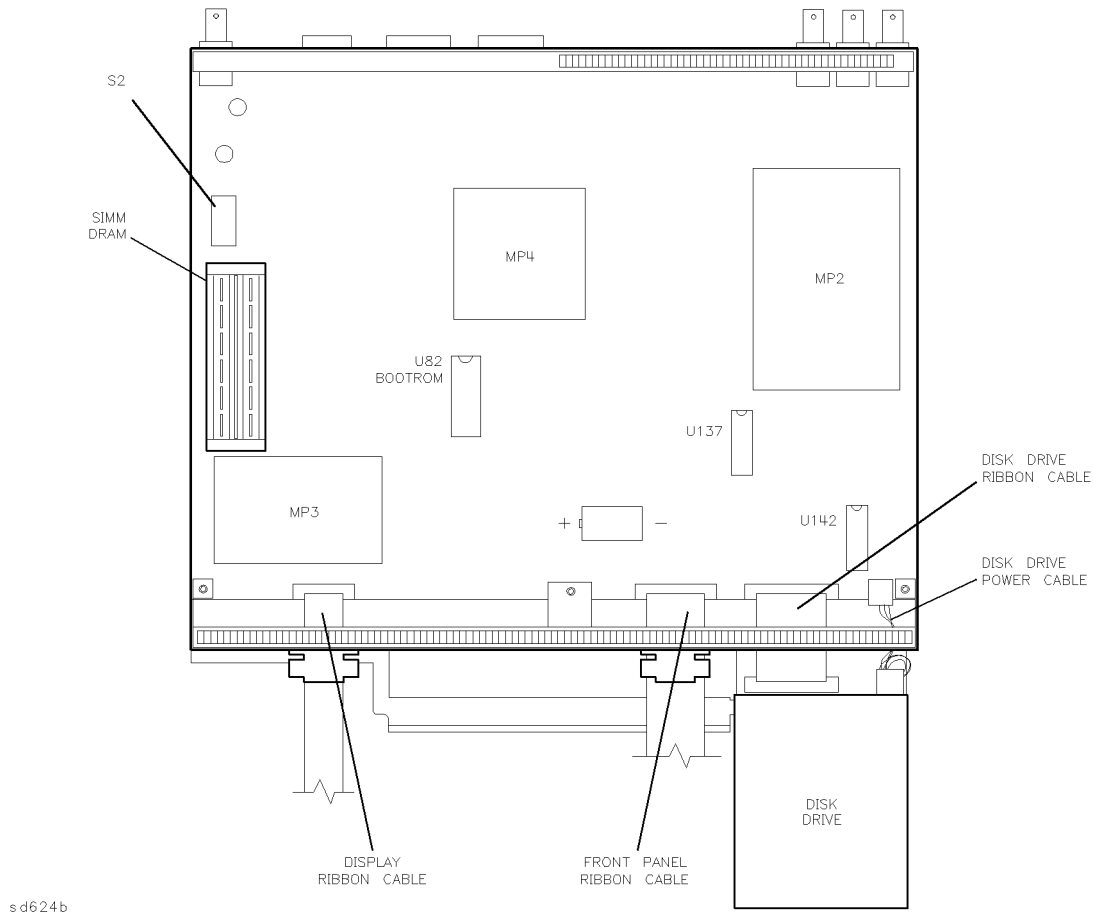

Figure 3-3. BootROM U82, Component Location

7. Transfer option ROMs (required for option 1C2 and some other options).
 - a. Locate and remove any of the following socketed option ROMs from the old CPU board (these ROMs are not present in all analyzers):
 - U137 for the IBASIC option (1C2), and
 - U142 for other options.
 Insert them into the replacement CPU assembly.
8. Transfer any SIMM memory.
 - a. Locate any SIMM DRAM memory and transfer it to the new CPU assembly making sure to insert them into the same corresponding location.

- b. If SIMMs are present, verify the switch S2 settings are also transferred to the new assembly.

Note As shipped from the factory, most analyzers do not have any SIMM memory.

9. Transfer the A8 3.5" internal disk drive assembly:

Remove the disk drive from the old board and install it on the replacement assembly.

10. Transfer all cable assemblies:

Remove all cable assemblies from the old board and properly attach them to the replacement board.

A3 Fractional-N/Reference Assembly Replacement

The A3 fractional-N/reference assembly consists of the main 10 MHz reference board and a fractional-N daughter board. These are pretuned as a set; do *not* attempt to order either board separately.

Before replacing any board, make sure the RCA phono cable plugs (Items numbered 5, 6, 7, and 8 in Table 7-5 of the “Parts List” chapter) are fully seated. If they are not seated, the board may not fit or it may generate spurs.

Figure 3-4 depicts an HP 8713B/14B. Though the HP 8711B/12B analyzer’s cable assemblies are slightly different, the assembly/disassembly procedures are the same.

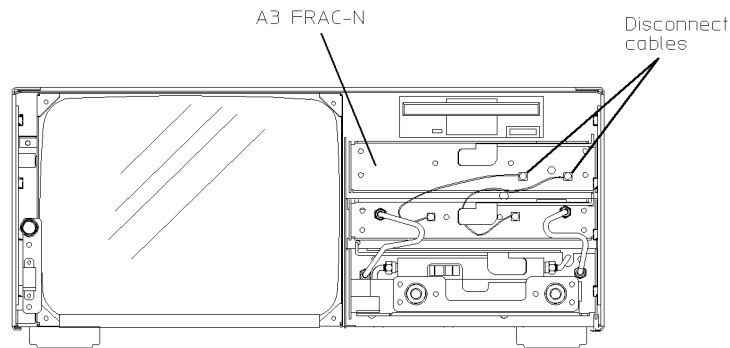

sd652b

Figure 3-4. Removing the Fractional-N/Reference Assembly

How to Remove the Fractional-N/Reference Assembly

1. Disconnect the power cord.
2. Remove the front panel assembly (see “How to Remove the Front Panel Assembly”). Remove the handle nut plate on the right side only.
3. Disconnect, if present, any cable from the EXT REF IN BNC connector on the rear panel.
4. Remove the nut and washer from the EXT REF IN BNC connector on the rear panel.
5. Disconnect the two flexible cables from the front of the assembly. See Figure 3-4.
6. Grasp the handle tab and pull forward to release the assembly. Once released, the assembly will easily slide out of its cavity.

A4 Source Assembly Replacement

There are four A4 source assemblies available for replacement. There are both 50 Ω and 75 Ω versions for the HP 8711B or HP 8712B. There are also 50 Ω and 75 Ω versions for the HP 8713B or HP 8714B. Make sure the correct version is ordered.

The source board comes in two different versions. One is for HP 8711B/HP 8712B analyzers, and the other is for HP 8713B/HP 8714B analyzers. Make sure the proper board is ordered.

How to Remove the Source Assembly

1. Disconnect the power cord.
2. Remove backplane cover by unscrewing the two hold-down screws and sliding the cover off.
3. Remove rear panel screw (SCREW 9) located to the right of the XA4J1 connector.
4. Remove the front panel assembly (see “How to Remove the Front Panel Assembly”).
Remove the handle nut plate on the right side only.
5. Disconnect the four cables from the front of the source assembly. See Figure 3-5.

Caution Be very careful when reconnecting the semi-rigid cables (Items numbered 1 and 4 in Table 7-1 and Table 7-2 in the “Parts List” chapter). They are not interchangeable. Ensure that one cable is not confused with the other. The possibility exists that the wrong cable can be forced onto the wrong connector, resulting in damage to the connectors/cables.

6. Grasp the handle tab and pull forward to release the assembly. Once released, the assembly will easily slide out of its cavity.

Note Insure that SCREW 9 is re-installed and secure when you have completed reassembling the analyzer.

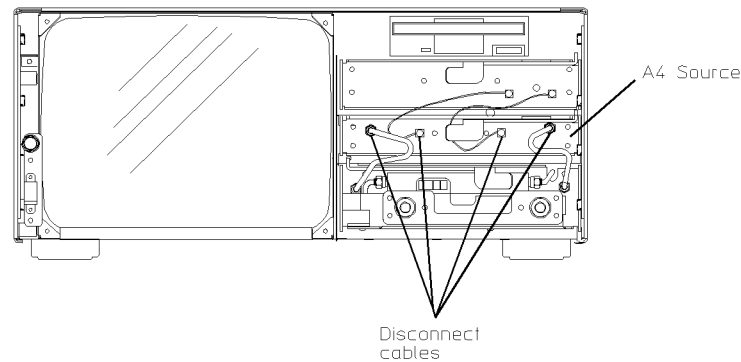

sd653b

Figure 3-5. Removing the A4 Source Assembly

A5 Receiver Assembly Replacement

Caution Please read the following carefully. Failure to follow instructions may result in an improperly operating analyzer.

Perform the following only at an approved ESD workstation.

There are four receiver assemblies available for replacement. There are both 50 Ω and 75 Ω versions for the HP 8711B or HP 8712B. There are also 50 Ω and 75 Ω versions for the HP 8713B or HP 8714B. Make sure the correct version is ordered.

If one or both RF port connectors are damaged, you *must* replace the plate that contains both connectors. Do *not* attempt to replace a single connector by itself. These connectors have been machine-pressed into the plate to prevent undesired rotation. It is not possible to duplicate this in the field.

The replacement A5 receiver assemblies are supplied in their minimal format which may not work in all instances depending upon installed options. Perform all of the required steps below, if applicable.

Note *For analyzers with option 1E1:*

If the analyzer contains the optional 10 dB step attenuator, it is necessary to remove the attenuator/board assembly from the original receiver and install it onto the new assembly. Carefully replace the attenuator assembly, ribbon cable (if required), and any semi-rigid RF coax cables.

For analyzers with option 1DA or 1DB:

If the analyzer contains the AM delay option, it is necessary to remove the AM delay board assembly from the original receiver and install it onto the replacement assembly. Carefully replace the AM delay assembly, ribbon cable (if required), and any semi-rigid RF coax cables.

How to Remove the Receiver Assembly

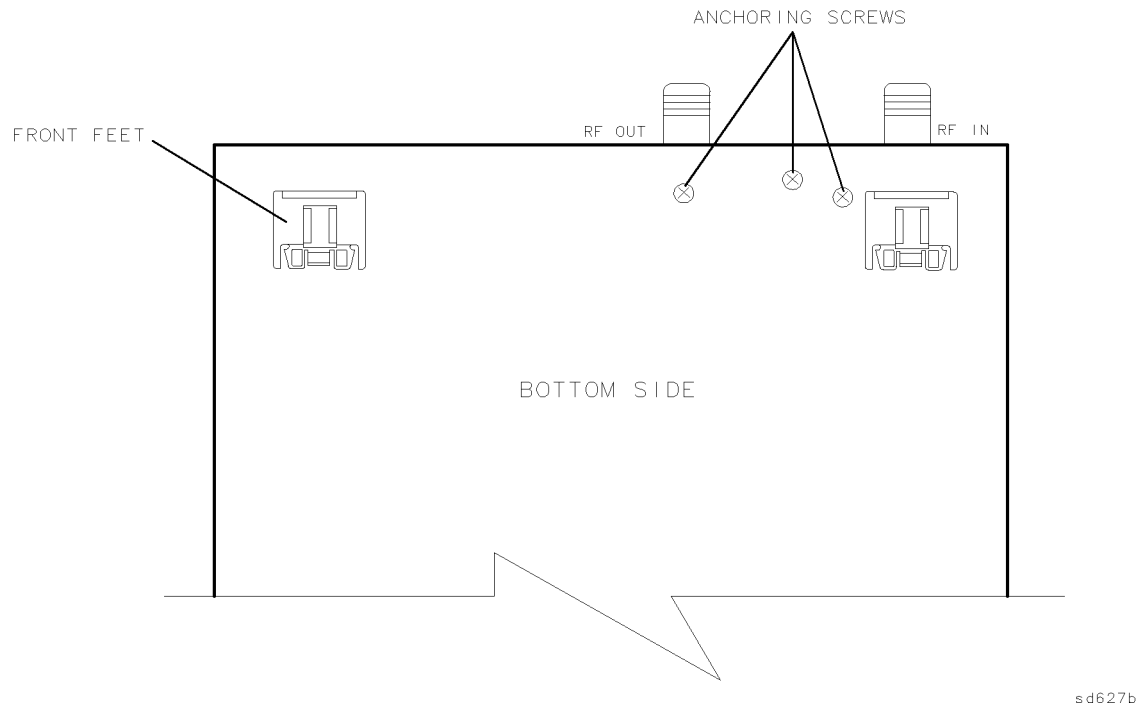

Figure 3-6. Anchoring Screw Locations for A5 Receiver Removal

1. Disconnect the power cord.
2. Disconnect any cables from the EXT DET x-input, EXT DET y-input, and AUX INPUT rear panel BNC connectors.
3. Remove nuts and washers from AUX INPUT BNC connector.
4. Remove the three anchoring screws on the bottom of the analyzer. See Figure 3-6.
5. Remove the front panel assembly (see “How to Remove the Front Panel Assembly”). Remove handle nut plate from right side only.
6. There are two semi-rigid cables connecting the A5 assembly to the A4 assembly. Completely loosen one nut on each cable where it connects to the A4 assembly, then separate the cable from the A4 assembly.

Caution Be very careful when reconnecting the semi-rigid cables (Items numbered 1 and 4 in Table 7-1 and Table 7-2 in the “Parts List” chapter). They are not interchangeable. Ensure that one cable is not confused with the other. The possibility exists that the wrong cable can be forced onto the wrong connector, resulting in damage to the connectors/cables.

7. Grasp the handle tab and pull forward to release the assembly. Once released, the assembly will easily slide out of its cavity.

A6 Power Supply Assembly Replacement

The power supply is a single assembly. The only lower level part available for replacement is the cooling fan.

How to Remove the Power Supply Assembly

1. Disconnect the power cord.
2. Remove the front panel assembly (see “How to Remove the Front Panel Assembly”).
Remove the handle nut plate on the left side only.
3. Remove the display enclosure (see the following section “How to Remove the Display Assembly”).
4. Remove the four screws along the rear edge of the display enclosure.
5. Lift open the display access panel and disconnect the two-wire cable from the power supply.
6. Withdraw the power supply from the housing.

A7 Display Assembly Replacement

The display consists of the CRT assembly and a matched circuit board. Both assemblies must be replaced at the same time.

How to Remove the Display Assembly

1. Disconnect the power cord.
2. Remove SCREW 7 (two places) as indicated on the rear-panel label.
3. Remove the two screws (located on the display side of the analyzer) from the bottom of the analyzer chassis.
4. Remove the front panel assembly (see “How to Remove the Front Panel Assembly”).
Remove handle nut plate on left side only.
5. Withdraw the enclosure 2 or 3 inches from its cavity.
6. Disconnect the ribbon cable from the jack behind the top of the CRT.
7. Withdraw the enclosure completely from its cavity.

Note

To replace the power switch or brightness control:

- a. Remove the display enclosure from the analyzer.
 - b. Locate the switch and brightness control at the left side of the display.
Remove both controls from the display flange.
 - c. Both the controls and their associated cables must be replaced as a unit.
-

A8 3.5" Internal Disk Drive Assembly Replacement

The disk drive is a non-repairable unit and must be replaced if it fails. However, before replacing the drive, try cleaning the drive with a suitable cleaning device, or by spraying it with clean compressed air. Most "failed" drives are only in need of a cleaning. If the drive must be replaced, you must reconfigure the jumpers as per Figure 3-7. Verify the position of the three jumpers and correct them if necessary. The jumpers should connect pins 2 and 3, pins 6 and 7, and pins 15 and 16.

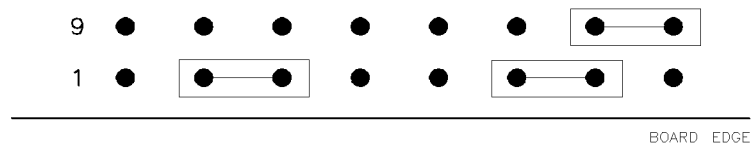

sd625b

Figure 3-7. A8 Disk Drive Jumper Configuration

How to Remove the 3.5" Disk Drive Assembly

1. Disconnect the power cord.
2. Remove the front panel assembly (see "How to Remove the Front Panel Assembly").
3. Remove the CPU assembly (see "How to Remove the CPU Assembly").
4. Remove the four screws anchoring the disk drive to the CPU assembly.
5. Disconnect the ribbon cable and power cable.

Attenuator Replacement

See "A5 Receiver Assembly Replacement."

AM Delay Modulator Replacement

See "A5 Receiver Assembly Replacement."

Post Repair Procedures

Table 3-1 describes the adjustments and performance tests that are required after replacing one or more of the analyzer's assemblies.

Table 3-1. Post Repair Procedures

Replaced Assembly	Required Adjustments	Suggested Verification Tests
A1 Front Panel	None	Functional Test Only
A2 CPU	Re-load correction constant file from disk OR (if CCs are not available): LO Power Correction ¹ Aux Input Correction Switched Gain Correction External Detector Correction Source Power Correction B Amplitude Correction Transmission (B/R) Correction Reflection (One Port) Correction R* Amplitude Correction R* Frequency Response Correction B* Amplitude Correction AM Delay ² AUX Input	Functional tests only OR: Broadband Frequency Response Dynamic Accuracy Absolute Power Accuracy Directivity Power Flatness
A3 Fractional-N/Reference	Frequency Accuracy Adjustment Fractional-N VCO Adjustment Fractional-N Spur Adjustment	Frequency Accuracy Spurious Signals
A4 Source	LO Power Correction ¹ Source Power Correction B Amplitude Correction Transmission Correction Reflection Correction AM Delay ²	Power Range and Flatness Spurious Signals
A5 Receiver	LO Power Correction ¹ Switched Gain Correction Aux Input Correction External Detector Correction Source Power Correction B Amplitude Correction Transmission (B/R) Correction Reflection (One Port) Correction R* Amplitude Correction R* Frequency Response Correction B* Amplitude Correction AM Delay ²	Power Flatness Broadband Frequency Response Dynamic Accuracy Spurious Signals Absolute Power Accuracy Directivity Gain Compression Noise Floor
A6 Power Supply	None	Power-on self tests
A7 Display	Check display intensity	Functional tests only
A8 3.5" Internal Disk Drive	None	Functional test only
Attenuator	Source Power Correction Transmission Correction Reflection Correction	Power Flatness Directivity
AM Delay Assembly	Source Power Correction Transmission Correction Reflection Correction AM Delay	Power Flatness AM Delay Modulator

1 Not required for HP 8713B and HP 8714B network analyzers.

2 Only required for analyzers with option IDA or IDB.

How to Order Parts

Refer to the chapter titled “Parts List.” Identify the part and its part number. To order the part:

1. Use the part number listed
2. State the quantity desired
3. Address the order to the nearest Hewlett-Packard sales and Service Office. See Table 10-1 in the “Safety, Warranty, and Assistance” chapter.

To save money or time, read the following paragraphs.

To order parts not listed, include the analyzer model number, complete analyzer serial number, description and function of the part, and quantity desired.

Save Money by Ordering R-E (Rebuilt-Exchange) Assemblies

If you need to replace an assembly and would like to save money, consider a R-E (rebuilt-exchange) assembly. These factory-repaired, tested assemblies are available on a trade-in basis. They meet all factory specifications required of a new assembly. They are designated (R-E) in the “Parts List” chapter.

Save Time by Calling (800) 227-8164

To order parts as fast as possible, call the above number Monday through Friday, 6 AM to 5 PM PST. You will contact HP parts specialists with direct on-line access to the parts listed in this manual. Four-day delivery is standard; one-day (hotline) delivery is available for an additional charge. Outside of the United States, contact your nearest HP office. See Table 10-1 in the “Safety, Warranty, and Assistance” chapter.

Troubleshooting and Block Diagrams

This chapter is divided into four main, symptom-related sections. Refer to the section that best describes the problem you are observing, based on the results of your initial observation.

Category 1 Failures:

- Dead or no response
- No display
- Unreadable display
- Error message/code displayed

Category 2 Failures:

- No error message, but nonfunctional measurement (i.e. through-line transmission trace is not flat and centered around 0 dB).

Category 3 Failures:

- Inaccurate (but reasonably functional) measurements.

Category 4 Failures:

- Peripheral device problems such as:
 - HP-IB problems
 - printer problems
 - keyboard problems

General Notes

Warning	<i>Always unplug the analyzer's line power before removing or installing an assembly.</i>
----------------	---

Caution	If you need to disassemble the instrument, be sure to work at an antistatic workstation and use a grounded wrist strap to prevent damage from electrostatic discharge (ESD). See Figure 4-1.
----------------	--

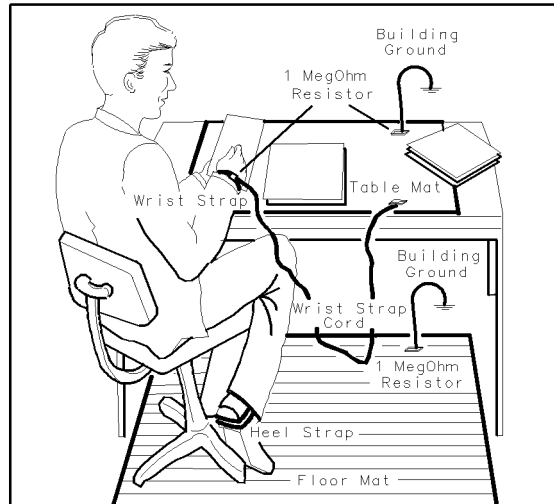

FORMAT46

Figure 4-1. Example of an Antistatic Workstation

- For disassembly procedures, see “Assembly Replacement.”

Warning **Some parts in the analyzer have sharp edges. Work carefully to avoid injury.**

- Before replacing an assembly, inspect the board for obvious, easy-to-fix defects. Examples include:
 - bent pins on ICs
 - no solder in holes around the edges of shields
 - cold solder joints

Service Kit

The service kit (HP part number 08712-60012) for the HP 8711B/12B/13B/14B analyzers contains several parts that are useful for adjusting and servicing the analyzer. The following parts are included:

- An extender board assembly that allows you to operate selected internal board assemblies outside the analyzer chassis.
- Two SMB extension cables, 12 inches long (30 cm).
- A modified 5/16-inch wrench for better access to SMA cable nuts.
- A 6-inch (150 mm) semi-rigid coaxial extension cable.
- A non-shielded display ribbon cable used to connect the display when the A2 CPU board is operated outside the chassis.
- A voltage reference source used to perform several adjustments. The source provides $\pm 0.5V$, $\pm 24mV$, and $+10V$ supplies.

How to Use the Extender Board

The A2, A3, A4, and A5 board assemblies can all be operated outside of the chassis with the extender board. This can be very helpful if you are troubleshooting a problematic board assembly.

The supplied display ribbon cable is needed to connect the display if the A2 CPU assembly is connected to the extender board.

The SMB extension cables may be needed for the A3 fractional-N/reference or A4 source assemblies.

The A4 source and A5 receiver assemblies will need two flexible SMA RF cables (not supplied) to make the analyzer fully operational while either of these boards are connected to the extender board.

To use the extender board, follow these instructions:

1. Loosen the two screws on the back cover.
2. Slide the cover to the right and remove it.
3. Attach the lower half of the extender assembly to where the cover was previously located.
4. Align the hold-down screws and tighten securely; the board will not function if not tightened sufficiently.
5. Attach the two ribbon cable connectors as shown in Figure 4-2.

The board under test plugs into the 96-pin connector. When properly connected, both the top half of the extender assembly and the attached board under test can rest on top of the analyzer.

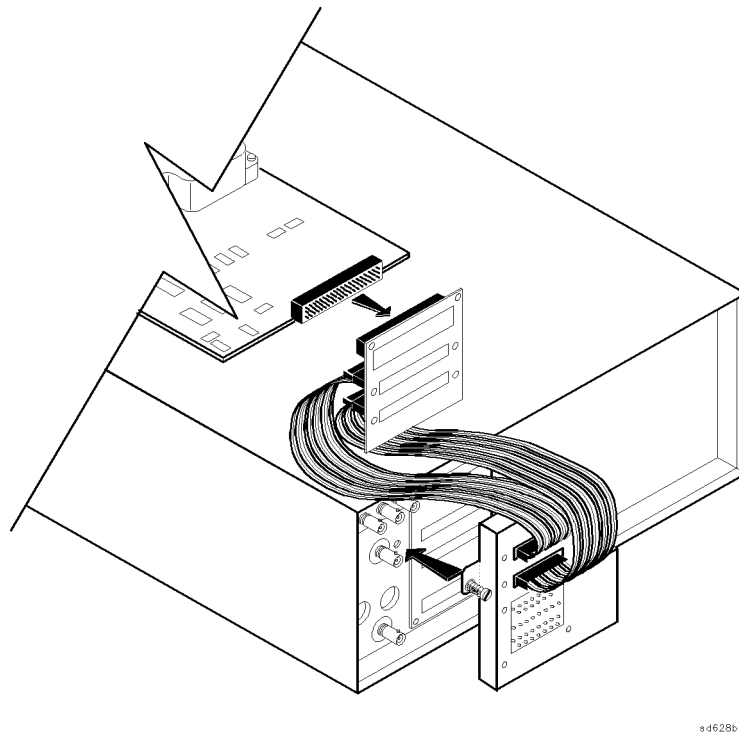

Figure 4-2. Connecting the Extender Board

Initial Observations - Normal Power-up Sequence

Prepare the analyzer for observation by performing these steps:

1. Disconnect all accessories and peripherals.
2. Remove the disk (if any) from the internal disk drive.
3. Connect a known-good cable between the RF OUT and RF IN ports.

Switch ON the analyzer and watch for the proper power-up sequence:

1. Immediately after the analyzer's line power is switched on, the disk drive light activates briefly and a "beep" is audible from the CPU.
2. The CRT lists the bootROM self-tests being performed. (The CRT may take a few seconds to warm up.) If all bootROM self-tests pass, the analyzer beeps twice.
3. The disk drive light illuminates briefly and the firmware loads from ROM.
4. The analyzer runs all of the remaining self-tests and the CRT displays the PASS/FAIL status of the self-tests.
5. During the next few seconds, these messages appear on CRT:
 - a. Initializing
 - b. Calculating correction coefficients
 - c. Initializing detector corrections
 - d. Other messages may appear briefly, depending on the analyzer's state at the time that the power was switched off.
6. Information on the model number, firmware revision, and installed options will be displayed. The graticule may also be displayed, depending on the analyzer's power-down state.

Press **(PRESET)**. The display should show a transmission trace (a flat line at 0 dB). If it does not, ensure the cable connecting the RF OUT port to the RF IN port is good as well as securely connected.

If the analyzer will not switch on, check the AC line power. Make sure that the line voltage selector (below AC power plug) is set correctly. Check the fuse.

If the analyzer does not go through the steps above, if any error messages appear, or if the problem persists, refer to the section titled "Category 1 Failures."

Note If any error is generated during the power-up sequence, the analyzer will halt after displaying the error message. At this point, if you press any key on the analyzer, it will attempt to resume operation. However, *erroneous or unstable operation may result*. The option of ignoring the error message is provided only as a troubleshooting aid.

Operator's Check

Perform the Operator's Check procedure in the "Performance Tests" chapter of this guide. It is a simple test of the analyzer's measurement capability. If the test passes and peripherals are not involved, duplicate the operating conditions under which the system failed and refer to the appropriate section in this chapter if the problem reoccurs.

Category 1 Failures - Dead or No Response, No Display, Unreadable Display, or Error Messages on the Display

This category of failure usually involves one of the following:

- a defective A6 power supply
- a defective A2 CPU
- Poor contact with the rear plane connector board
- A digital failure in any board assembly
- A defective display

Troubleshooting A6 Power Supply Assembly Problems

Begin here if the problem appears to be power supply related.

Check the Rear Panel LEDs

Switch the analyzer's line power ON. Check the condition of the two LEDs visible through the hole in the rear panel to the right of the AC power plug.

If the green LED is on and the red LED is off:

This represents a normal condition. Continue with "Measure the Power Supply Voltages" to confirm that the power supplies are functioning properly.

If neither LED is on:

Check the line fuse, located in a holder above the AC power jack, and replace it with the spare provided if necessary. Check the AC power line. If the LEDs are still off, replace the power supply.

If the green LED is on, the red LED is on steadily, and the fan is off:

Check the line voltage selector switch, located below the AC power jack. If it is correct, remove the power supply/display assembly and make sure that the cable from the on/standby switch to the power supply assembly is connected.

With the power supply/display assembly outside the analyzer, plug it in and switch the analyzer's line power ON..

If the fan is still off:

Check the four green power supply LEDs visible from the right side of the display enclosure (as viewed from the front). If the LEDs are on, the fan is probably broken. Replace the fan or the entire power supply assembly.

If the green LED is on, the red LED is on steadily, and the fan is on:

Go to "Measure the Power Supply Voltages." Note that it is normal for both the green and red LEDs to be on when the power switch is in STANDBY, but not when the switch is in the ON position.

If the green LED is on, and the red LED is blinking:

The power supply is in shutdown. Remove the power supply/display assembly from analyzer, plug it in and switch the analyzer's line power ON.

If the red LED is still blinking:

Replace the power supply.

If the red LED is now off:

Go to the following section “Remove Assemblies” (the supply is being loaded down by another assembly).

Measure the Power Supply Voltages

Remove the backplane cover from the rear panel. Figure 4-3 shows the pinout for J1. There are four main supplies, each with its own return, plus the standby voltage which powers the nonvolatile SRAM on the CPU board. Measure the voltages with a voltmeter. Values should be within 5% of nominal for all but the +13V supply.

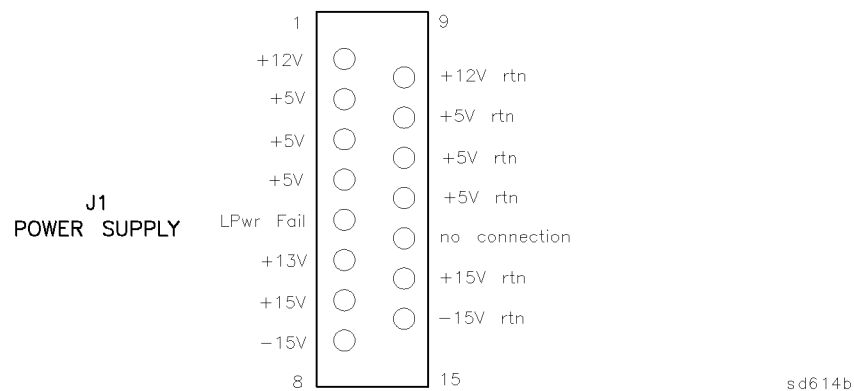

Figure 4-3. Power Supply Connector, as Viewed from Rear Panel

If the voltages are not correct:

Remove the power supply/display assembly, plug in the AC power, and switch the analyzer’s line power ON. Check the four power supply LEDs visible from the right side of the display enclosure (as viewed from the front).

If one or more LEDs are off:

Replace the power supply.

If all the LEDs are on:

Reseat the power supply/display assembly, making sure there’s a good connection to the rear panel. Measure the voltages again. If the problem persists, check connectors on the power supply and on backplane board.

If the voltages are correct, but there is a probe power problem:

Remove the front panel and check the fuses on the back of the front-panel PC board.

Continue with the “Troubleshooting Digital Group Problems” section.

Remove Assemblies

If your problem has not been solved at this point in the troubleshooting process it is highly probable that one of the assemblies is causing the power supply to shut down. This may be caused by the other boards having bad contact with the backplane. Give each board a push to

make sure it is firmly seated. If the problem persists, remove the assemblies one at a time, and note which one is causing the shutdown. Refer to the “Assembly Replacement” chapter of this guide for disassembly instructions.

Note It is possible for the flexible metal “fingers” or a backplane connector pin to break off and cause a short, so check for loose pieces of metal.

Verify that none of the pins on the back-panel connector are bent. This is a common cause of shorted supplies.

Suggested order for assembly removal (easiest to hardest):

1. A1 front panel assembly
2. A7 display assembly (remove the ribbon cable while it is outside the analyzer; reinstall and see if the power supply is still shut down). If A7 display assembly appears to be causing shutdown, open the display enclosure cover (see Table 7-13 titled “A7 Display Assembly and Cable Locations” in the “Parts List” chapter of this guide) and make sure the board assembly is firmly seated.
3. A3 fractional-N/reference assembly
4. A4 source assembly
5. A5 receiver assembly
6. A2 CPU/A8 disk drive assembly

Troubleshooting Digital Group Problems

Error During Power-up

If there is no beep at power-up, but the CRT display is normal:

The problem is probably in the sound generator or speaker on the CPU board. Check the sound generator chip (U143) and the speaker (LS1), or replace the CPU board.

If there is no beep at power-up and no CRT display:

The problem is most likely one of three conditions:

- No power to CPU board (no CPU LEDs on),
- CPU chip not plugged into its socket (CPU LEDs will be on),

OR

- Another fault in the CPU assembly.

Look through the TEST RESULTS hole on the rear panel to see if the LEDs are lit. If none of the LEDs are lit, push the CPU board all the way into the backplane connector to ensure a good connection. Note that it is also possible for the board to have a bad or intermittent backplane connection and yet receive enough power to activate the LEDs.

If the LEDs are on, remove the CPU board (remove rear panel screws first). Remove the shield from the 68020 CPU (in the center of the CPU board) and make sure it is properly seated in its socket. Then reinstall the CPU board, making sure to push it all the way in so that it connects properly with the backplane. If there is still no beep at power-up and CPU LED continues to display an “8,” replace the CPU (U56) or the entire CPU board.

If the disk drive light does not illuminate:

Make sure the power (3-wire) cable and ribbon cable are connected from the disk drive to the CPU board. Check the cables. The problem can be either a bad disk drive or bad drive circuitry on the CPU. If a 3.5" disk drive controller error message appears during power-up, replace the CPU. Otherwise, replace the disk drive.

If there is no CRT display:

Adjust the front panel intensity knob clockwise to increase the brightness. If there is still no CRT display, remove the display and check the ribbon cable connection to the CPU board. If the problem persists, check the output from the VIDEO OUT BNC on the rear panel with an oscilloscope. Check for activity in this signal. The frequency and magnitude may vary.

If the VIDEO OUT signal appears good:

The problem is most likely either the display assembly or the ribbon cable.

If the VIDEO OUT signal appears bad:

The video circuitry is probably bad. Replace the CPU or confirm video signals. See the following paragraph.

To confirm video circuitry problems:

Place an antistatic mat on top of the analyzer. Remove the CPU and place it on top of an antistatic mat. Use a service extender (provided with the service kit) board to power the assembly while it is outside the analyzer. Switch the analyzer on and make sure the green VIDEO ON LED next to the display ribbon cable connector is on.

Check these signals:

- HSYNC signal at TP12: 24.1 kHz TTL signal
- VSYNC signal at TP13: 60 Hz TTL signal

If either of these is not normal, try replacing U101 and U102 or replace the entire CPU board.

If an error occurs while firmware is being loaded (after 2 beeps are heard):

Reload the firmware from disk by inserting the firmware disk into the internal disk drive and switching the analyzer's line power ON. Press **BEGIN** at the Load firmware? query. The process will take a few minutes. Watch the CRT for information during the loading procedure.

If the analyzer locks up during or after the firmware loading, try clearing the SRAM by cycling the analyzer's line power (first, switch the analyzer OFF, then back ON). While the analyzer is going through its self-tests (Main and SIMM DRAM tests or shortly afterwards), press **PRESET** a few times. When the analyzer pauses after performing the CPU main self-tests it displays a query about zeroing the non-volatile SRAM. (Note the caution message!) Press **BEGIN** to zero the SRAM. Reload the firmware from disk again.

If a self-test fails:

The analyzer indicates the number of the first failed self-test in two ways:

- An error message appears on the CRT, if possible
- "Test Status" LEDs display a number code corresponding to the number of the failed test.

Test Status LEDs. These include one red LED, one green LED, and a 7-segment LED which display the digits 0 through 9. The red and green LEDs are located to the left of the 7-segment LED when viewed from the rear panel.

Test Status LEDs code.

- Red LED and 7-segment LED on: test numbers 1 through 9, as shown on 7-segment display.
- Green LED and 7-segment LED on: tests 10 through 19. Add 10 to value shown on 7-segment display.
- Only green LED on: all self-tests passed.

Table 4-1 lists the power-up self-tests by number, with a description of the error messages and troubleshooting information. Some of the troubleshooting hints may require the use of a service extender board. Reference designators for main ICs (e.g. U32) are noted on the PC boards. Note that replacing the defective board is always an option; you need not troubleshoot to the component level.

Check the Test Status LEDs, then locate that test number in the table to determine what to do. For test numbers above 19, the name of the test is usually in the failure message, so look for the test name in the Table 4-1. Refer to the “Service Related Menus” section of this guide for detailed descriptions of each test.

Note Not all error messages are listed in the table. Many error messages describe the problem clearly and require no further explanation, so they are not included in this guide.

Some error messages are only partially reproduced, because the remainder of the message is specific to the error (e.g. provides address at which the failure occurred).

<num> indicates either an address or a value. These may be in decimal or hexadecimal notation.

Table 4-1. HP 8711B/12B/13B/14B Self-Tests

Test	Test Name	Applicable Error Messages and Notes
1	680x0 Processor	Errors begin with “CPU TEST FAIL.” Remove CPU board, and ensure U56 is seated its socket. If test still fails, replace CPU board or U56.
2	BootROM Checksum	Errors: Bad checksum table at ... ROM Checksum Failure in bank ... Checksum Table is Blank. ROM may be blank. Unexpected ROM Id at <num> Bad ROM count in Checksum table ... Bad ROM size in Checksum table ... This tests checksum of boot ROM chip: Replace CPU board or U82.
3	Main ROM Checksum	Errors: Same as for test #2. This tests checksum of main flash EPROM. Reload firmware from floppy disk. If test still fails, replace the CPU board or check the EPROM chips U51-U54 and U78 to U81.

Table 4-1. HP 8711B/12B/13B/14B Self-Tests (continued)

Test	Test Name	Applicable Error Messages and Notes
4	Main DRAM	<p>Errors: Memory size too small. Bus error. At address <num>, write <num> read <num>. RAM bit errors: <num> RAM refresh errors: <num></p> <p>Test checks size of main DRAM, writes/reads test patterns. Check reported size of DRAM on power-up display. Memory size should be about 4 MB. Replace CPU board or check the following: DRAM control circuitry U38-U41 DRAM data interface chips U69, U84 DRAM address MUX U37, U58, U59, U86, U88 DRAM chips U61-U68</p>
5	SIMM DRAM	<p>Errors: same as for test #4.</p> <p>Test checks size of SIMM DRAM, writes/reads test patterns. Check reported size of SIMM DRAM on power-up display. Normally 0.</p> <p>Make sure SIMMs (if any) are installed properly: they must be installed in pairs, and larger size ones should be in bank 0. Check switch setting on S2. All switches should be open (up), except for switch 1 if bank 0 contains 256 kB SIMMs, switch 2 if bank 0 contains 1 MB SIMMs, or switch 3 if bank 0 contains 4 MB SIMMs. Use of four 256 kB SIMM DRAMs is not supported.</p> <p>If problem persists, replace CPU or check the following: Control circuitry U31, U38 Data buffers U76, U77 Address MUX U50, U74, U75</p>
6	340x0 GSP Processor	Test not implemented
7	GSP Video	Test not implemented
8	(number not used)	Test number not used because test status LED powers up with this as default. An "8" on the LED indicates the 68020 was unable to power-up and execute basic instructions.
9	DSP SRAM	<p>Errors: same as for test #4.</p> <p>Checks program SRAM used by the digital signal processor. Typical memory size about 65536 bytes. Replace CPU, or check SRAM chips U79 and U94; and chips U73, U41, U85, U93, U60, and U89.</p>
10	320C25 DSP Processor	Test not implemented.
11	68020 & 320C25 Communication	Test not implemented.
12	Backplane Bus	<p>Errors: Reference clock not toggling. Unable to gain control of DSP bus. Cannot perform backplane bus tests. Access error: wrote <num>, read <num>, right shift = <num> Source board: Failed self-test. Receiver board: Failed self-test.</p> <p>Test reads version numbers from fractional-N/ref, source, and receiver boards. Checks for 5 MHz clock from fractional-N/reference board. Make sure all boards are pushed in and making good contact with backplane. Check 10 MHz output from A3J3. If not found, see "Troubleshooting Source Group Problems." Replace CPU or check U21 and U22.</p>

Table 4-1. HP 8711B/12B/13B/14B Self-Tests (continued)

Test	Test Name	Applicable Error Messages and Notes
13	Non-volatile SRAM	<p>Errors: SRAM battery test FAILED - Saved states lost. SRAM battery test ERROR - Cannot access SRAM.</p> <p>Tests integrity of battery-backed SRAM, detects loss of power to SRAM. Writes/reads pattern to part of SRAM. Remove CPU board and check battery BT1, replace if needed. Replace CPU board or check U124 controller, U83 SRAM, and U125 voltage regulator.</p>
14	Digital IF Control	<p>Test not implemented.</p>
15	CPU Support Circuitry	<p>Errors: 68901 MFP chip test FAILED. Stuck interrupt.</p> <p>Tests 68901 Multi-Function Peripheral chip and interrupt circuitry. Replace CPU board, or check U133.</p>
16	Analog Bus	<p>Errors: CPU +5V supply is out of range! Vpp Flash Supply is out of range!</p> <p>Tests analog bus ADC on CPU board. Replace CPU, or check power supplies, U109 voltage regulator for Vpp.</p>
17	Real Time Clock	<p>Tests ability to write/read to real time clock.</p>
18	Front Panel Interface	<p>Errors: Front panel keyboard FAILED. Command write timeout. Read input timeout. Clear input buffer failed. Echo byte test failed.</p> <p>Tests front panel control processor. Replace CPU board or check U136, U138.</p>
19	Floppy Disk Controller	<p>Error: Floppy Disk controller FAILED. Error number <num></p> <p>Tests controller chip, accesses registers, writes commands and verifies response. Replace CPU or check U140.</p>
20	HP-IB Interface	<p>Error: HP-IB test FAILED. Data bit error on these bits: (followed by list)</p> <p>Tests HP-IB interface, writes to chip and verifies response. Test not performed if anything connected to HP-IB. Replace CPU board or check U9, U10, U34.</p>
21	RS-232 Interface	<p>Errors: RS-232 interface test FAILED. Bus error. Cannot access. Data bit error on these bits: (followed by list)</p> <p>Tests RS-232 DUART chip, accesses registers on chip, checks for clock input. Replace CPU board or check clock U4, DUART chip U5.</p>

Table 4-1. HP 8711B/12B/13B/14B Self-Tests (continued)

Test	Test Name	Applicable Error Messages and Notes
22	DIN Keyboard Interface	<p>Errors: 8042 DIN Keyboard test FAILED Problem with DIN Keyboard Power Supply! Check Fuse.</p> <p>Tests DIN keyboard control processor. Replace CPU board or check clock Y53, processor U13.</p>
23	Centronics Interface	<p>Errors: Centronics port test FAILED. Strobe bit error. Printer reset bit error. Printer select bit error.</p> <p>Test writes to and reads back three printer control output lines. Replace CPU board or check U2, U3, U35.</p>
<p>Note: Tests numbered: 8, 11, and 14-17 are not run during power-up.</p>		

Error Occurs During DSP Initialization or Calculating Coefficients

Clear the Nonvolatile SRAM

Cycle the analyzer's line power. While the analyzer is going through its self tests (Main and SIMM DRAM tests or shortly afterwards), press the **PRESET** key a few times. The analyzer will pause after performing the CPU main self-tests and ask if you want to zero the nonvolatile SRAM. (Note the caution message!) Press **BEGIN** to do so. Continue if the error persists.

Measure the 5 MHz Reference Signal

The DSP requires this signal from the fractional-N/reference assembly for proper operation. This signal is routed on the backplane board. Make sure that the fractional-N/reference assembly is pushed all the way in and making good contact with the backplane. Measure the 5 MHz signal at J6-C24 on the backplane board with an oscilloscope. If the signal is present, remove the CPU board and the shield over the DSP chip (on the right side of the board). Make sure that the TMS 320C25 microprocessor is properly seated in its socket. If the problem persists, refer to "Testing the DSP Circuitry" to check the DSP, or replace the CPU board.

If there is no 5 MHz signal at the backplane:

Check the reference board. If an external reference signal is used, make sure it's a 10 MHz reference with a level of at least -5 dBm.

If the internal 10 MHz reference is being used, check the output at A3J3 to verify that the crystal oscillator is working. If the 10 MHz signal is not present, replace the A3 fractional-N/reference assembly.

Front Panel Problems

If the analyzer appears to power-up normally but will not respond to keystrokes, verify that none of the keys are stuck. If the front panel keys are still not responding properly, remove the front panel and make sure the ribbon cable is properly connected between the front panel assembly and the CPU.

Inspect the keypad and the PC board. Replace if either assembly is defective. The RPG can be replaced separately. Inspect the ribbon cable closely and verify that it is in good condition. Try removing the ribbon cable clamp located on the CPU board to verify this is not causing a short.

If an inspection of the front panel assembly reveals no obvious defects, replace the CPU board.

Other Power-Up Problems

A power-up sequence problem can also be caused by a problem with the SRAM. These problems can have many symptoms, since the symptom will depend on where the analyzer was in its power-up sequence when the bad data was encountered. Try clearing the SRAM (see previous section for instructions). If the problem persists, the DRAM is probably bad and the CPU board needs to be replaced.

If the analyzer intermittently will not power-up, but cycling the line power restores normal operation, then replace A3U20.

Other Error messages

In some unusual cases, an error message similar to that shown below may occur. This may indicate a defective component, an anomaly in the firmware code, or an unspecified operating condition. In general, however, this message should never be seen. If it does appear, follow the instructions, then cycle power. If the problem reoccurs, try clearing SRAM (see previous page). If the problem persists, contact your local HP sales or service office for further instructions.

```
*****
UNRECOVERABLE ERROR:

Please report the error "xxxx.nn"
to your local HP Service or Sales office.

To help HP fix this problem quickly,
please note what you were doing when
this error occurred. Any related operating
information might be helpful, such as:
    Measurement type, # points,
    IBASIC and SCPI commands,
    printer and disk info, etc.

Thank you for reporting this error.
Cycle power to continue.
*****
```

The error number is in the form "xxxx.nn", where *nn* is a number from 0 to 31, and *xxxx* is one of these names:

```
ARRY DBUG FPKP HPIB IBAS IBSL IBfp IBkr
MMGR PLOT SELB TCH1 TCH2 TIME idle root
```

Examples include: ARRY.04, FPKP.08, and TCH1.10.

Category 2 Failures - No Error Message, but Nonfunctional Measurement

This group includes the A3 fractional-N/reference and A4 source board assemblies. Typical problems include:

- Phase lock lost
- Power output problems
- Other RF problems

Troubleshooting the A3 Fractional-N/Reference Assembly

Check the Output Power

Connect a power meter or spectrum analyzer to the RF OUT port. Set the analyzer to a CW frequency of 300 kHz. Change power level and see if output power changes correctly. Repeat at several different frequencies (i.e. 1 MHz and 50 MHz).

If there is no source output or noisy trace at about -25 dB:

The source may be disconnected from the receiver. Check the cable connections between the source and receiver (torque to 10 inch-lbs). If the problem persists, go to “Phase Lock Problems” below.

If the signal is not steady (i.e. appears unlocked), or if the frequency doesn't change properly):

Go to “Phase Lock Problems.” If the signal appears okay but the power levels are incorrect, go to “Power Problems.” Otherwise, proceed to the “Troubleshooting Receiver Problems.”

Phase Lock Problems

There are three phase lock loops on the source board: RF1, RF2, and the source LO. As you can see from the overall block diagram at the end of this chapter, the source LO is mixed with the RF1 signal to produce the source RF output. It is also mixed with the RF2 signal to produce the receiver LO output.

Since both the RF1 and RF2 loops use the 10 MHz reference signal from the A3 fractional-N/reference board, first verify the accuracy of that signal.

To verify the 10 MHz reference signal:

Remove the handles and front panel. Connect an oscilloscope and/or frequency counter to A3J3 (the connector on the right) to measure the 10 MHz output from the A3 fractional-N/reference board.

Note	The output signal must be measured with a 50Ω load attached. Typically this signal consists of a 2V, 15 ns pulse into 50 ohms. The frequency should be 10 MHz ± 50 Hz.
-------------	--

- Signal correct: continue on to the following section “To Verify Fractional-N Output.”
- Signal present but not accurate: perform the “Frequency Accuracy Adjustment” procedure in the “Adjustments” chapter of this guide.

- No signal found: verify that external reference has not been selected by pressing **(MENU)** and making sure that **Ext Ref on OFF** is displayed. Replace the fractional-N/reference board, or refer to “Detailed Source Troubleshooting” below.

Detailed Fractional-N/Reference Troubleshooting

To troubleshoot the 10 MHz reference signal: if a service extender board is available, put the A3 fractional-N/reference board on the extender board.

- Verify power supplies: $-5V$ at TP1 and TP2.
- Check for the internal 10 MHz signal at TP7 and U5 pin 8. If this is not found, replace the A3 fractional-N/reference board or U5, the 10 MHz clock.
- Check TP8 for a 10 MHz signal. If this is present, Q1 is most likely bad. Replace the A3 fractional-N/reference board.

Note **To Troubleshoot the Fractional-N Board (Daughter board of the A3 assembly):**

The fractional-N board is also used in the HP 3325A. Refer to the *HP 3325A Operating and Service Manual* (HP part number 03325-90002), for more detailed troubleshooting information if you wish to troubleshoot to the component level.

To Verify Fractional-N Output:

Set the analyzer to the CW frequencies in the Table 4-2, and check the fractional-N output at A3J1 (connector on the left).

The typical amplitude of this signal should be in the 0 to +4 dBm range. Any harmonics should be better than -16 dBc.

Table 4-2. Source Frequency Versus Fractional-N Frequency

HP 8711B/12B		HP 8713B/14B	
Source Frequency	Fractional-N Frequency	Source Frequency	Fractional-N Frequency
300 kHz	36.567187 MHz	300 kHz	31.993251 MHz
500 MHz	44.375 MHz	500 MHz	38.825087 MHz
1.3 GHz	56.875 MHz	1.3 GHz	49.762587 MHz
		2.0 GHz	43.336806 MHz
		3.0 GHz	57.008681 MHz

- Fractional-N output OK: replace source board.
- Fractional-N output not OK: press **(MENU)** **Spur Avoid** and make sure dither is OFF, since the frequencies will be different for dither ON. Remove the A3 fractional-N/reference assembly and check all cables. Perform the “Fractional-N VCO Adjustment” (see the “Adjustments” chapter of this guide). If problem persists, replace the A3 fractional-N/reference assembly.

Troubleshooting the A4 Source Assembly

Note The following measurement values assume a properly adjusted instrument. If no correction constants have been loaded, the power levels given may vary a few dB either way.

Measure the RF output signal directly out of the source board at A4J4. Press **PRESET** and set the output frequency to CW 50 MHz; trigger hold mode. The RF output should be at 50 MHz ± 250 Hz. The exact power level of this will vary depending upon the installed options but should typically be in the +1 to +5 dBm range. Set the frequency to 3000 MHz (1300 MHz for HP 8711B/12B) and measure the power again. This power level should be in the range of +2 to +9 dBm, again depending upon the installed options. Frequency accuracy should be within 15 kHz (6500 Hz for HP 8711B/12B).

Now check the LO output from the source at A4J1. Using the same conditions as above, measure the LO when the RF out is set to 50 MHz. The LO should always be 27.778 kHz **above** the RF signal. Repeat for 3000 MHz (1300 MHz for HP 8711B/12B). Power levels for the LO should be in the +6 to +14 dBm range, regardless of frequency.

Troubleshooting the A5 Receiver Assembly

Connect a cable between the RF OUT and RF IN ports, then press **PRESET**. The display should show a flat trace at about 0 dB. Press **CHAN 1 Reflection**. The display should resemble Figure 4-4 (Figure 4-5 for HP 8713B/14B), although the exact pattern and magnitude of the ripples will depend on the cable being used.

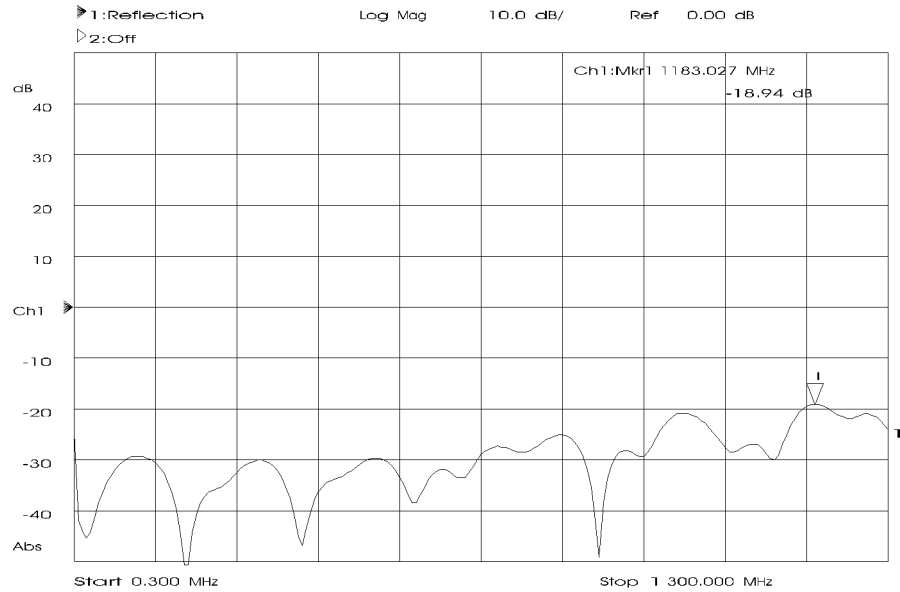

sd615b_c

Figure 4-4. HP 8711B/12B Reflection Measurement with Through Cable

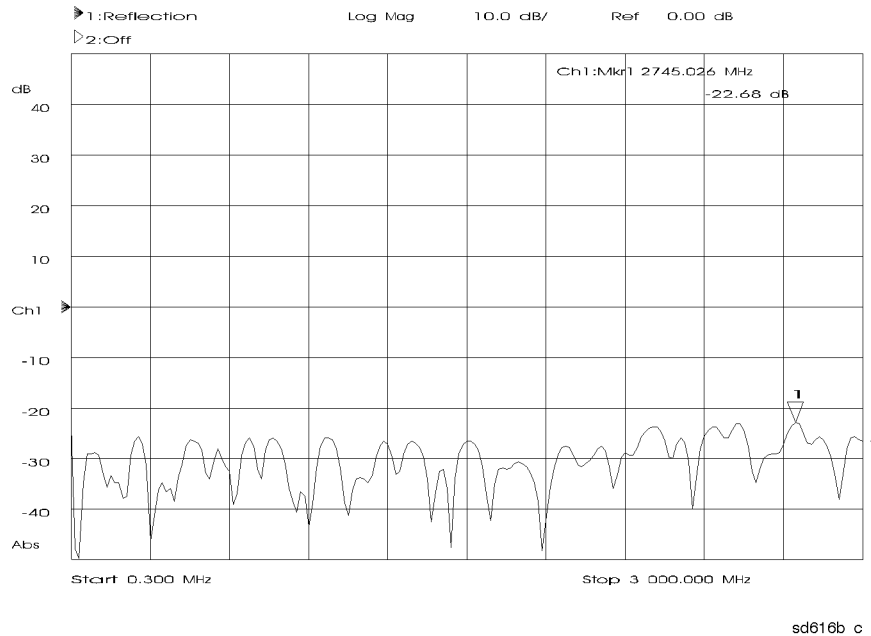

Figure 4-5. HP 8713B/14B Reflection Measurement with Through Cable

Press **CHAN 1** **Detector Options** **Narrowband Internal** and select inputs **A**, **B** and **R** one at a time. Inputs **B** and **R** should be flat at about 0 dB. Input **A** should look somewhat similar to the reflection trace in Figure 4-4 (Figure 4-5 for HP 8713B/14B). Now press **CHAN 1** **Detector Options** **Broadband Internal** and select inputs **R*** and **B***. **R*** should be a fairly flat line at 0 dB. **B*** should be within ± 3 dB of a flat line at 0 dB. If any of these fail, and assuming the source board is functioning properly, then the receiver is probably bad (see paragraph below); replace the receiver.

If the **B*** input looks bad, then the **B*** detector diodes may be damaged. Sometimes this is accompanied by poor input match at the RF IN port. If this is the case, it is possible to replace these diodes separately, thus saving time and money. These diodes will generally be the first components to fail if the maximum input level is exceeded or if it is subjected to excessive ESD. Refer to “A5 Receiver Diode Replacement,” below.

A5 Receiver Assembly Diode Replacement

Caution You must perform this procedure *only* at static-safe workstation to prevent damage from electrostatic discharge (ESD). See Figure 4-1.

If the analyzer’s RF IN port is overpowered by excessive RF or by ESD, the detector diodes may be damaged or shorted. If damaged by ESD, degradation may take place over a period of time. This will cause bad input match causing a through-line cable to no longer appear flat. In addition, selecting internal broadband detection on **B*** will show low or nonexistent power. **R*** should not be affected much and should still show a flat line at 0 dB if the RF OUT port is terminated in a correct load. It is also possible that the protection diodes could be damaged. Replacing just these diodes is fairly easy in the HP 8711B/12B, but you must be experienced in replacing surface mount components. Replacing these diodes in the HP 8713B/14B is much more difficult. The parts are smaller, and great care must be exercised to ensure that all excess solder and flux is removed before attaching the new diodes. Do not attempt to replace diodes

on the HP 8713B/14B unless the procedure is performed by a qualified technician who is very proficient with small surface mount components and all the proper equipment is available.

For the HP 8711B/12B:

Detector diodes CR1, CR2 (HP part number 1900-0262)

Protection diodes CR36, CR37 (HP part number 1900-0096)

For the HP 8713B/14B:

Detector diodes CR53, CR54 (HP part number 1900-0293)

Protection diodes CR45, CR46, CR47, and CR48 (HP part number 1900-0273)

When replacing the detector diodes, note the polarity of the existing parts and make sure the new ones are oriented the same! See Figure 4-6 (for HP 8711B/12B) or Figure 4-7 (for HP 8713B/14B) for component location. You will have to remove the receiver shield to access these parts. On the HP 8713B/14B, CR47 and CR48 are mounted in the same location as CR45 and CR46, but on the opposite (top) side of the board. All adjustments listed for the A5 receiver assembly replacement should be performed after replacing the diodes. See Table 3-1, "Post Repair Procedures."

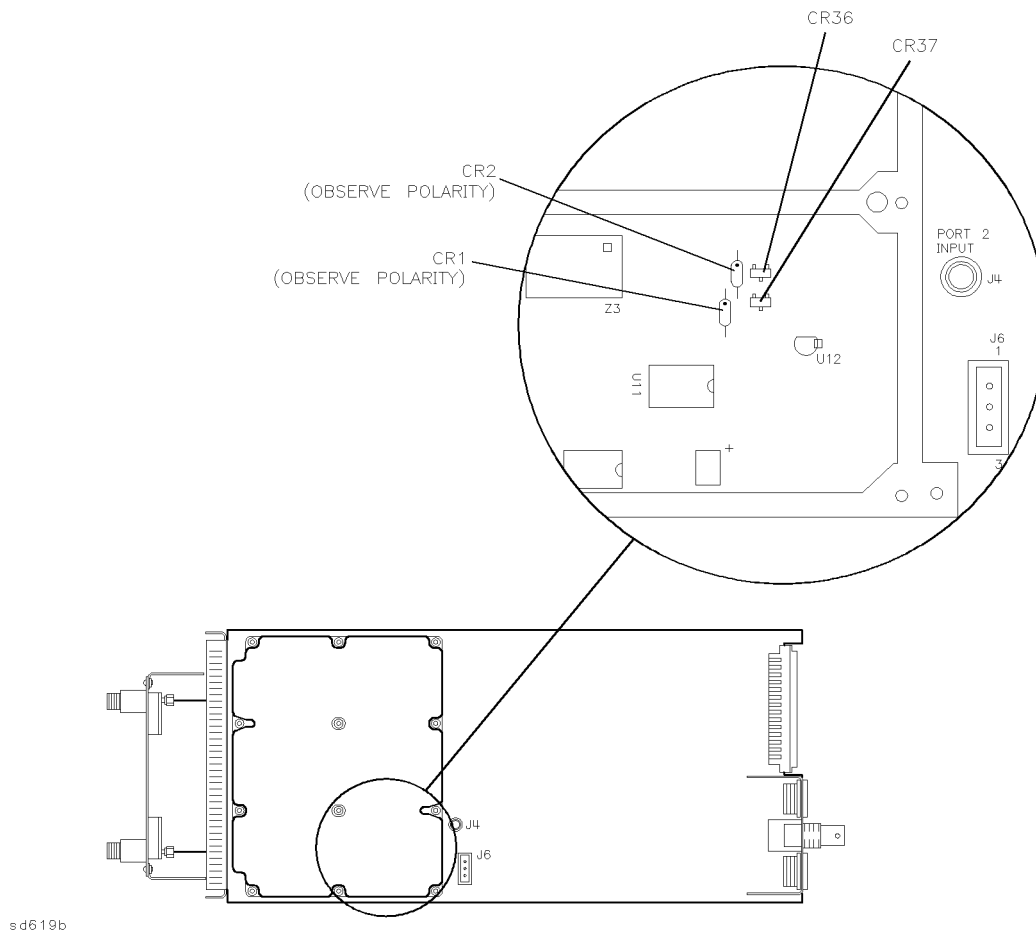
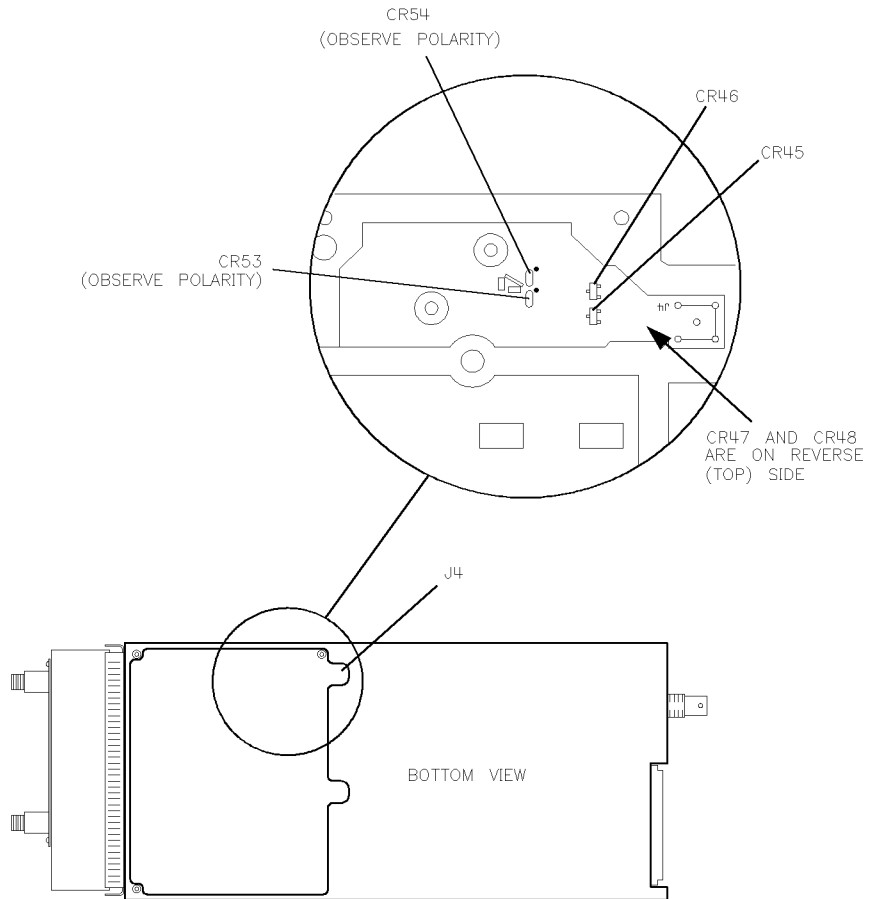

Figure 4-6. HP 8711B/12B A5 CR1, CR2, CR36, and CR37 Component Locations



sd621b

Figure 4-7.
HP 8713B/14B A5CR45, CR46, CR47, CR48, CR53, and CR54 Component Locations

Trace at ± 200 dB

A flat trace at ± 200 dB indicates that the DSP is getting no data (or zero data.) Make sure that the receiver and CPU boards are making proper connections to the backplane. The problem is most likely either in the ADCs on the receiver board, or the DSP circuitry on the CPU board. To determine the exact cause, test the DSP circuitry.

Testing the DSP circuitry:

Locate J32, an 8x3 jumper just above the DSP shield on the A2 CPU board assembly. Temporarily place the jumper in the “TEST” position as shown on the board. This replaces the receiver’s ADC clock and data signals with a clock signal and fake data generated on the CPU board. The instrument should power up normally. Observe the CRT.

- If random noise data trace around 0 dB is observed, the CPU is functioning properly. Replace the A5 receiver assembly or go to “Detailed Receiver Troubleshooting” below.
- If no random noise data trace is observed around 0 dB: replace the A2 CPU.

Detailed Receiver Troubleshooting

To Confirm an ADC Problem when the Trace is at ± 200 dB:

Check for activity at the following pins on the receiver’s backplane connector.

Pin Number	Signal
C27	ADC_DAT1
A27	ADC_CLK1
C26	ADC_DAT2
A26	ADC_CLK2

If these signals are not present, replace the receiver assembly.

Category 3 Failures - Inaccurate (but reasonably functional) Measurements

Troubleshooting Spurious Responses and Inaccurate Data

Spurious Signals

Perform the “Spurious Signals” test procedure in Chapter 1, “Performance Tests.” If the test fails, perform the “LO Power Correction” and “Fractional-N Spur Adjustment” procedures in “Adjustments,” Chapter 2. Then run the “Spurious Signals” test again.

To check RF at A4J4:

Connect a spectrum analyzer to the source RF output at A4J4. Set the network analyzer to a series of CW frequencies (e.g. 10 MHz, 500 MHz, 1 GHz in hold- trigger mode) and use the spectrum analyzer to check for harmonics and other spurs. The specification for harmonics is <-20 dBc below 1 MHz and <-30 dBc above 1 MHz. Non-harmonic spurious signals are not specified, but typical values are the same as for harmonics. Connect the spectrum analyzer to the receiver LO output at A4J1 and repeat.

If there are spurs in source RF output only OR receiver LO output only (not both):

Replace the A4 source assembly.

If there are spurs in source AND receiver outputs:

The problem may be due to spurs in the 10 MHz or fractional-N inputs to the A4 source assembly. Fractional-N spurs are not specified, so use the “Fractional-N Spur Adjustment” to improve the spur performance, but do not replace the fractional-N board unless these spurs cause the analyzer to fail its harmonics specifications.

To check 10 MHz at A3J3:

Use an oscilloscope to look for a 2V 10 MHz pulse. If a spectrum analyzer is used, a blocking capacitor should also be used in conjunction, since the 10 MHz output is DC coupled.

If the 10 MHz signal has spurs:

- Replace the A3 fractional-N/reference assembly.

Otherwise:

- Replace the A4 source assembly.

Spurs in the Data Trace

Some spurs are unavoidable in this network analyzer configuration. Most of the predictable spurs can be eliminated by either using either the Spur Avoid or the Dither option in the Spur Avoid menu. See your instrument's *User's Guide* for more information. The location (in MHz) of these spurs can be approximated by the formula:

$2340/N$ where $N = 2, 3, 4 \dots$ etc.

Use a spectrum analyzer or power meter to check the output of the source at the RF OUT port to see if the spurs are in the RF output signal. If they are, go to "Troubleshooting Source Problems."

Perform the "Switched Gain Correction" adjustment in the "Adjustments" chapter of this guide. If the problem persists, replace the A5 receiver assembly.

Inaccurate Data

Check adapters, cables, and test port connectors for damage. Gauge the test port connectors. Ensure that the cables between the A4 source and A5 receiver assemblies are properly connected.

Perform the following receiver corrections found in the "Adjustments" chapter of this guide, as indicated by where the data problems occur. If the problem is in both narrowband and broadband mode, refer to the "Adjustments" chapter of this guide to determine the proper order for performing the adjustments. If the problem is only in broadband mode, the problem could be bad detector diodes, see "A5 Receiver Assembly Diode Replacement."

Narrowband mode problems:

Switched Gain Correction
B Amplitude Correction
Transmission Correction
Reflection Correction

Broadband mode problems:

Switched Gain Correction
External Detector Correction
R* Amplitude Correction
R* Frequency Response Correction
B* Amplitude Correction

If data seems to drift, check the uncorrected performance of the analyzer. Connect a good load to the RF OUT port. Press **PRESET** **CHAN 1** **Reflection** **SYSTEM OPTIONS** **Service** **Meas Cal Options** **Meas Cal Off** **MARKER** **Marker Search** **Mkr—Max**. The marker value should be less than (below) -15 dB. Remove the load and connect a through cable between the RF OUT and RF IN ports. Press **Mkr—Max**. The marker value should be less than -12 dB. If these are bad, replace the A5 receiver assembly or see "A5 Receiver Assembly Diode Replacement" earlier in this chapter. Test port cable can also cause drift.

If data is okay with just a through cable connected (after preset) but bad in an application, check for the following:

Verify that you are looking at the expected measurement; especially check:

- Data vs. memory or data/memory display
- Channel 1 vs. channel 2 data trace
- Channel 1 vs. channel 2 y-axis labels (when both channels are on)
- "Rel" vs. "Abs" y-axis scale
- System bandwidth
- Narrowband vs. broadband mode

Make sure the span is not too narrow. This may cause interpolation errors with the default or full-band calibrations. Perform a user-defined calibration at the desired frequency range.

Mismatch errors can cause inaccuracies up to a few tenths of a dB. This is usually noticeable as ripple in a low-loss transmission display and is typically more noticeable in an HP 8711B/12B than in an HP 8713B/14B. Excessive ripple can indicate poor source or input match. Measure the match using the performance tests. If OK, try using attenuators to improve match.

Receiver Power Problems

Check all cables and cable connections on the receiver board; tighten if necessary.

If the problem is caused by a power hole, try moving the cables to see if the power hole moves or disappears. If it does, the cable is probably defective.

If the analyzer has a step attenuator and the problem only occurs with the attenuator engaged (<0 dBm for the HP 8711B/12B and <-5 dBm for the HP 8713B/14B), replace the step attenuator assembly. Otherwise, replace the A5 receiver assembly.

Category 4 Failures: Peripheral Device Problems

DIN Keyboard

If a DIN keyboard interface test failure was reported during power-up, there may be a problem with the +5V power supply for the DIN keyboard. Disconnect the keyboard, remove the CPU board, and check the +5V fuse next to the DIN connector. If necessary, replace it with the spare fuse provided.

Verify that the keyboard is connected properly. Make sure that the keyboard is compatible with the analyzer. The analyzer should work with HP DIN keyboards that are U.S. English versions, and most (but not all) IBM PC/AT compatible keyboards.

Connect the keyboard to a computer or another analyzer to see if it is functioning, or try using a different keyboard. If the keyboard works with other instruments, replace the CPU board.

RS-232 Printers and Plotters

If an RS-232 interface problem was reported during power-up (with no peripheral connected), there may be a problem with the RS-232 DUART chip, U5, or its 3.6864 MHz clock, U4. Replace the CPU board.

Make sure the printer's or plotter's line power is switched ON, that it has paper and pens, that its pinch wheels are down, etc. Plotters should not be in VIEW mode. Verify that the RS-232 device has been selected as the hardcopy device by pressing **(HARDCOPY) Select Copy Port**. The first line on the CRT shows the current device selection. The second line shows the baud rate, parity, and handshake information. If any of this is incorrect, enter the correct information. Refer to the printer or plotter manual for proper parameters. Refer to your analyzer's *User's Guide* for more details on hardcopy options.

Try to make a print or plot from another instrument or a computer to confirm that the printer/plotter is working. If it is, replace the CPU board.

Centronics® (Parallel) Printers and Plotters

If a Centronics interface problem is indicated during power-up (with no peripheral connected), there may be a problem with the Centronics control chips (U2, U3, U35). Replace the CPU board.

Make sure the printer's or plotter's line power is switched ON, that it has paper and pens, that its pinch wheels are down, and so forth. Plotters should not be in VIEW mode. Verify that the Centronics device has been selected as the hardcopy device by pressing **(HARDCOPY) Select Copy Port**. The first line on the CRT shows the current device selection. The second line should say "Centronics." If this is incorrect, enter the correct information. Refer to your analyzer's *User's Guide* for more details on hardcopy options.

If everything seems okay but you still cannot print or plot, remove the CPU board and check jumper J45, near the HP-IB and parallel connectors at the rear of the board. Make sure the jumper is in the "RUN" position instead of "TEST."

Try to make a print or plot from another instrument or a computer to confirm that the printer/plotter is working. If it is, replace the CPU board.

HP-IB Systems

If an HP-IB interface problem is indicated during power-up (with nothing connected to the HP-IB port), there may be a problem with the HP-IB controller chip (U9) or the interface chips (U10, U34). Replace the CPU board.

Check the analyzer's HP-IB functions with a known working peripheral such as a plotter, printer, or disk drive. Press **PRESET** **SYSTEM OPTIONS** **HP-IB System Controller** to allow the analyzer to control the peripheral. Check the HP-IB address on the peripheral, then set the analyzer to recognize this address by following the instructions in the next section.

HP-IB Problems with Printers or Plotters

For HP-IB printers or plotters, press **HARDCOPY** **Select Copy Port** and select the appropriate HP-IB device. The currently selected device is shown on the first line of the display, and for HP-IB devices, the HP-IB address is shown on the second line.

To change the address, press **Hardcopy Address** and enter the correct value (from 1 to 30).

Note The default HP-IB address recognized by the analyzer for both printers and plotters is 5, but the factory default address of most printers is 1.

Make sure the printer or plotter has line power switched on, that it has paper and pens, that its pinch wheels are down, and so forth. Plotters should not be in VIEW mode. Press **Prior Menu Start** to do a print or plot. If the result is not a copy of the display (as selected by **Define Hardcopy**), suspect HP-IB problems in the analyzer.

HP-IB Problems with Disk Drives

For disk drives, press **SAVE RECALL** **Select Disk Configure Ext Disk** and set the correct address, disk unit, and disk volume numbers. Default values for all three are zero.

Press **Prior Menu External Disk** to select the external disk drive. The second line should begin with "EXT:".

Press **Prior Menu Save State** to store a file to the disk. If this is not successful, suspect HP-IB problems in the analyzer.

General Checks for HP-IB Systems

If the analyzer does not respond to an external controller, verify that the analyzer is in talker/listener mode. The analyzer cannot respond if it is in system-controller mode.

Make sure the controller is using the proper select code and addresses.

Be sure HP-IB cable length limits are not exceeded. See your analyzer's *User's Guide* for more detailed information.

Refer to the "HP-IB Programming" chapter of the *Programmer's Guide* to troubleshoot programming problems. Replace the CPU board if the analyzer appears to have an HP-IB problem.

Service Related Menus

Introduction

This chapter describes the functions of the service key menus. These menus are used to test, verify, adjust, control, and troubleshoot the analyzer. Internal diagnostics and adjustments include self-tests and adjustment tests. The service functions allow you to put the analyzer into different states to help with troubleshooting.

The service menu is accessed by pressing **SYSTEM OPTIONS** **Service**. Refer to Figure 5-1 for the service key menu maps.

Also included in this chapter are miscellaneous service functions and HP-IB commands. Procedures to clear nonvolatile memory (SRAM) and to load firmware are included in the “Miscellaneous Service Functions” section. Equivalent HP-IB commands for some of the service menu keystrokes are found in the “HP-IB Command Reference for Service” section.

Note The functions that appear under the **Service Utilities** menu are provided as a convenience for service personnel. When these features are used, *the response of the analyzer is not specified.*

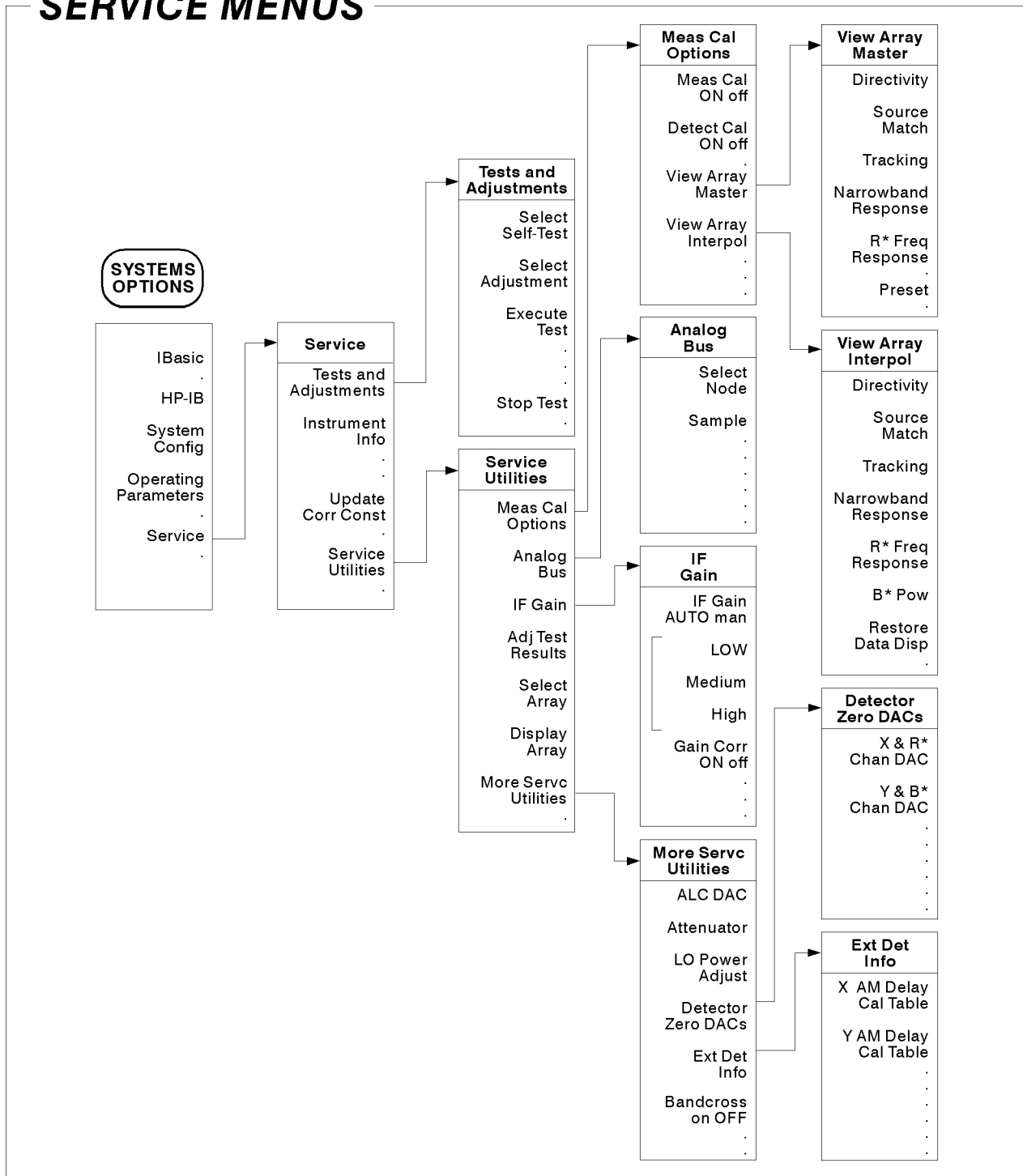

SERVICE MENUS



sd613b_c

Figure 5-1. The Service Key Menus

Tests and Adjustments Menu

Select Self-Test: Allows you to select a diagnostic self-test. Tests may be selected by entering the number of the test with the keypad, or using the front-panel knob or / keys to scroll through the list of tests. The number, description, and test status of the currently selected test are shown. Possible test status notations are: “PASSED,” “FAILED,” and “NOT DONE.” See “Self-tests” for a listing of all the tests and their descriptions.

If any test fails, refer to the “Troubleshooting and Block Diagrams” chapter.

Some tests are run only during power-up and the results of these tests will be displayed when the test is selected. However, these tests cannot be executed from this menu.

Select Adjustment: Allows you to select an adjustment. Adjustments are listed in numerical order. The adjustments can be performed in numerical order, but a more convenient order is shown in the “Adjustments” chapter. To select an adjustment, use the numeric keypad to enter the adjustment number, or use the front-panel knob or up/down arrow keys to scroll through the list. The number, description, and test status of the currently selected test are shown. Possible test status notations are: “PASSED,” “FAILED” and “NOT DONE.” See “Adjustments” for a listing of the adjustments and their descriptions.

Execute Test: Executes the selected test or adjustment.

Stop Test: This stops any test that is currently running.

Select Self-Test Menu

Internal tests can be used in troubleshooting the analyzer. Only the ones marked with an asterisk (*) in Table 5-1 are executed during the power-up sequence. The pass/fail status of these tests can be checked by scrolling through the list of self-tests. Also, if any test fails during power-up, the number of the first test to fail will be displayed on the “Test Results” LED which is visible through an opening in the analyzer’s rear panel.

Note There are two LEDs to the left of the seven-segment “Test Results” LED on the rear panel of the analyzer. The red LED is on for self-tests 1 through 9, and the green LED is on for tests 10 through 19. If all tests pass, the green LED will be on, and the red LED and the seven-segment LED will be off.

Table 5-1. HP 8711B/HP 8712B/HP 8713B/HP 8714B Self-Tests

Test Number	Test Name	Description
*1	680x0 Processor	Executes internal tests of 68020 main CPU. Checks all registers. Checks logic, math, shift/rotate, and bit manipulation instructions.
*2	BootROM Checksum	Checksum of bootROM to verify bootROM firmware code.
*3	Main ROM Checksum	Checksum of flash EPROM to check main firmware.
*4	Main DRAM	Writes a series of test patterns to the main DRAM and reads them back. Checks size of main DRAM.
*5	SIMM DRAM	Tests SIMM DRAM by writing to the DRAM and then reading the data back. Checks size of SIMM DRAM.
*6	340x0 GSP Processor	Performs a test of the TMS 34010 graphics system processor. Tests the display video RAM (VRAM).
*7	GSP Video	Tests the video circuitry.
8	(Not used)	This test number is not used because the test status LED powers up with the number "8" as the default. If there is a problem with the 68020 CPU, this "8" will remain displayed on the LED.
*9	320C25 Program SRAM	Checks the program SRAM used by the TMS 320C25 digital signal processor.
*10	320C25 DSP Processor	Tests the TMS 320C25 digital signal processor.
11	68020 and 320C25 Communication	Not implemented.
*12	Backplane Bus	Tests the ability of the 68020 to access the other boards through the backplane assembly.
*13	Non-volatile SRAM	Tests the integrity of the contents of battery-backed SRAM. Detects loss of power to the SRAM.
14	Digital IF Control	Not implemented.
15	CPU Support Circuitry	Tests various circuits that are required for the main processor (68020) to operate. Tests 68901 MFP chip (timers, interrupts). Attempts to clear and disable all interrupts. Tests each interrupt signal to the 68020 to make sure that none of them are asserted.
16	Analog Bus	Tests the analog bus control circuitry and +5V and EPROM Vpp on the CPU board.
17	Real Time Clock	Tests the real time clock and tries to access registers on the chip.
*18	Front Panel Interface	Tests the front panel control processor. Tries to access registers on the chip.
*19	Floppy Disk Controller	Tests the 3.5" internal disk controller chip. Tries to access registers on the chip. Writes commands to the chip, and verifies correct response. Also steps the floppy disk drive's head from track 0 to 9, and back to 0, to test the ability to find track 0.
*20	HP-IB Interface	Tests the HP-IB interface circuitry. Tries to access registers on the chip. Writes commands to the chip, and verifies correct response.
*21	RS-232 Interface	Tests the RS-232 DUART chip. Tries to access registers on the chip. Checks for missing clock input to the chip.
*22	DIN Keyboard Interface	Tests the DIN keyboard control processor. Tries to access registers on the chip.
*23	Centronics Interface	Tests the Centronics interface circuitry. Writes to three main printer control output lines, and reads them back.

**Table 5-1.
HP 8711B/HP 8712B/HP 8713B/HP 8714B Self-Tests (continued)**

Test Number	Test Name	Description
24	Front Panel Key	Prompts user to press any keys and displays information on the key pressed. Press PRESET three times to exit.
25	Erase Non-Volatile SRAM	Tests all locations of battery-backed SRAM by writing zeroes. This erases existing data.
26	Source PLL Lock	Not implemented.
27	X External Detector ID	Not implemented.
28	Y External Detector ID	Not implemented.
29	RS-232 Port	Prompts user to connect a printer or terminal, and then sends characters to the port.
30	Centronics Port	Prompts user to connect a printer, and then sends characters to the port.
31	DIN Keyboard Port	Prompts user to connect a DIN keyboard. Displays feedback on detected key presses.
32	HP-IB Port	Prompts user to disconnect HP-IB cable. Tests HP-IB hardware. Prompts user to connect a printer, and then sends characters to the port.
33	Test TTL Pass/Fail Bit Test	Prompts user to disconnect cable and then tests the hardware. Prompts user to ground the BNC and then tests the hardware.
34	Test TTL User Bit Test	Prompts user to disconnect cable and then tests the hardware. Prompts user to ground the BNC and then tests the hardware.
* Denotes a test run during power-up.		

Select Adjustment Menu

Adjustments generate correction constants (CCs) which compensate for the hardware performance of the analyzer. Correction constants are stored in flash EPROM along with the firmware. The data is copied to RAM during power-up. Running an adjustment test modifies the data in RAM, but it does not alter the data in EPROM.

To store the new CCs into EPROM:

1. Store the CCs to disk.
2. Clear the EPROM by reloading the firmware.
3. Recall the CCs from disk back into the RAM.
4. Store the CCs into EPROM.

Refer to the "Adjustments" chapter for details on how to perform all necessary adjustments.

Table 5-2. HP 8711B/12B/13B/14B Network Analyzer Adjustments

Adjustment Number	Title	Comments
100	Set Serial Number	Not implemented; serial numbers can only be set over HP-IB. Always indicates "Not Done."
101	LO Power Correction	Sets a DAC that varies the receiver LO output from the source. This ensures that the receiver mixers are getting the correct power level. Not applicable for the HP 8713B and HP 8714B.
102	Switched Gain Correction	Sets the low and high gain corrections for the receiver, which are needed for accuracy at low input power levels.
103	External Detector Gain Correction	The external X and Y detectors convert the detected power level into a voltage for the analyzer's receiver. In this adjustment, known voltages are applied to the detector input ports. The analyzer then generates correction constants for the receiver to use in interpreting the detector voltage level.
104	Source Power Correction	Source power correction. Generates power correction arrays for both the ALC and step attenuator (if installed).
105	B Amplitude Correction	B amplitude correction. Corrects B narrowband input so that it reads 0 dBm properly.
106	Transmission Correction	Transmission correction. Performs transmission cal to correct B/R to read 0 dB.
107	Reflection Correction	Reflection correction. Performs one-port cal to correct for narrowband reflection (A/R) measurements.
108	R* Amplitude Correction	R* amplitude correction. Generates absolute power lookup table for the R* input at 30 MHz.
109	R* Frequency Response Correction	R* frequency response correction. Generates frequency response correction for the broadband R* input.
110	B* Amplitude Correction	B* amplitude correction. Generates absolute power correction table for the broadband B* input at 30 MHz. The B* input power is varied from -30 to +18 dBm in 2 dB steps for this test. An external controller or IBASIC is required to run this test.
111	Auxiliary Input Correction	Auxiliary input correction. Corrects for offset and gain of the auxiliary input circuitry.
112	AM Delay Source Power Correction ¹	Corrects for loss in the AM delay circuitry.

1 Options 1DA and 1DB only

Results of several adjustments can be viewed by selecting **Adj Tests Results**. While this information was designed more for factory use (and can vary considerably from unit to unit), the information regarding the date and time of the last adjustment performance/modification can be very useful. This is updated each time an adjustment is performed. However, this date will be lost if the correction constants are not stored to EEPROM before the analyzer's line power is cycled. Date format is as defined under the **Set Clock** menu.

Instrument Info

Displays a window with the following information:

- Analyzer model and firmware revision
- BootROM version
- Analyzer serial number
- Installed options
- System impedance
- Installed memory

Update Corr Const Menu

For a complete description of when and how to use these keys, refer to “Storing and Recalling Correction Constants” in Chapter 8. The following is a brief description.

Install CC From Disk: Loads permanent copy of correction constant data from disk to EPROM. This key combines the functions of **Load CC from Disk** and **Store CC to EPROM**.

Help Menu: Displays a banner which describes the keys of this menu.

Load CC From Disk: This copies the contents of the correction constant file from the internal floppy disk drive into RAM. You cannot select an alternate disk drive. It allows you to copy a partially modified set of data into RAM and then continue with the rest of the adjustments.

Store CC To Disk: At power-up, correction constants are copied from the flash EPROM to a RAM buffer. Any changes to the correction constants are made to the buffer only. Pressing this key creates a disk file that contains the correction constants from the buffer. This file is always written to the internal disk drive, regardless of the disk drive selected using the save/recall functions. The file will be written over any existing file with the same name.

Store CC To EPROM: This alters the nonvolatile correction constants stored in the analyzer. The flash EPROM must be cleared first via firmware update. If not, you are told to store the correction constants to disk and update the firmware first. If the flash EPROM is clear, the correction constant data is transferred from the buffer into the EPROM.

Note

This copies all the adjustment data. If an adjustment test has not been done, the default values are put in EPROM and the only way to replace them with real adjustment data is to:

1. Do the adjustment
2. Press **Store CC To Disk**
3. Reload the firmware
4. Press **Load CC From Disk**
5. Press **Store CC To EPROM**

The **Install CC From Disk** softkey and **Store CC To EPROM** will be ghosted (dimmed) if data has already been stored to EPROM.

Service Utilities Menu

This menu allows manual control of several sections of the A4 source and A5 receiver assemblies. This can be a helpful tool in troubleshooting these circuits.

Caution Most of these utilities *are for factory use only*. Modification of any values or settings *can result in improper operation or inaccurate results*. If in doubt as to the status of any settings, simply cycle the analyzer's line power. These settings will then be defaulted to the correct values.

Meas Cal Options: Goes to the Measurement Calibration Options menu. From this menu you can activate/deactivate the measurement calibrations and detector calibrations, as well as access the View Array Master and View Array Interpolate menus (described in detail later).

Analog Bus: Goes to the Analog Bus menu.

IF Gain: FOR FACTORY USE ONLY.

Adj Test Results: Results of several adjustments can viewed by selecting

Adj Tests Results. While this information is designed for factory use and can vary considerably from unit to unit, the date and time that the last adjustment was done or modified can be helpful information. This is updated each time an adjustment is performed. However, this date will be lost if the correction constants are not stored to EEPROM before power is cycled. Date format is as defined under the **Set Clock** menu.

Select Array, **Display Array**: These two selections are virtually identical and both display the same data. Information displayed is the stored correction for the indicated parameter. Assuming no adjustments have been performed since power was cycled, this represents the correction constants stored in EEPROM.

Viewing this data is useful in determining the measured raw performance of the analyzer, as well as the quality of the adjustment procedure used to store the correction constant data. Since this data represents the correction constants determined by performing the adjustments, it is also an indication of how the adjustments were performed. If any of these arrays show significant discontinuities, suspect either a hardware problem in the analyzer, or a hardware problem in the equipment used to perform the adjustment.

Data displayed is always the full band correction regardless of the current start/stop frequency settings. Absolute values are generally offset by a significant amount, so meaningful information can only be derived from the relative values. Table 5-3 lists all of the analyzer's thirty-nine correction arrays along with a brief description and typical value ranges.

More Svc Utilities: Allows you to manually control the ALC DAC, step attenuator, LO power, and the autozero DACs for the R* and B* inputs.

Table 5-3. HP 8711B/12B/13B/14B Correction Constant Storage Arrays

Array Number	Description	Typical Correction	Comments
0	One-port Directivity	< 10 dB (HP 8713B/14B) < -5 dB (HP 8711B/12B)	This data is related to the raw directivity of the reflection port coupler (but does not equal it).
1	One-port Source Match	< -14 dB	This represents the source match of the reflection port.
2	One-port Tracking	<5 dB variation	This is related to the frequency response of the A (reflection port) input.
3	B Amplitude Response (narrowband)	<5 dB variation	This is related to the frequency response of the transmission port input (B input).
4	B/R Amplitude Response (narrowband)	<5 dB variation	This is related to the frequency response of the transmission port input (B input).
5 - 32	ALC Corrections for the 7 attenuator steps, 0 through 6, and DAC values 1000, 1500, 2000, and 2500 for each	See Comments	These curves all represent the power correction tables generated mostly by adjustment #104. For each the seven different attenuator settings, four different ALC settings are measured for flatness. From this, the ALC correction table is generated. Since each trace only has about 20 points, it may appear slightly discontinuous; this is normal. For units without an attenuator (without option 1E1) the correction should be flat for any attenuation value other than zero. Higher ALC values represent higher power levels.
33	B* Amplitude Linearization (broadband)	See Comments	This is the correction curve for the absolute B* power measurement. It represents voltage (Y-axis) out vs. power in. It is normal for the last few horizontal divisions to be a flat line.
34	R* Amplitude Linearization	See Comments	As above, but for the R* diode.
35	B* Frequency Response	0	Not implemented. Always a flat line at 0.
36	R* Frequency Response	0 ±3 dB	Represents the frequency response of the R* diode. A downward spike at the beginning of the trace is normal.
37	AM Delay Insertion Loss	0.5 to 2.5 dB	Represents the increased insertion loss of the AM delay modulator when in the ON position. An upward spike at the beginning of the trace is normal.
38	B* Diode Slope	See Comments	A typical trace will be flat for the first and last few divisions. This trace represents the change in slope of power-in vs. voltage out. The slope is constant (zero) for both the log and linear portions of the diode curve. Only the transitional area will show something other than a flat line.
39	R* Diode Slope	See Comments	As above but for the R* diode.

Meas Cal Options Menu

The analyzer uses array of calibration data to improve the measurements made by the hardware. This menu allow you to disable the calibration, and view the calibration data arrays.

Meas Cal ON off: Determines whether cal arrays are used in processing data.

Meas Cal OFF will switch OFF both user-performed cals and the default factory cal. This includes transmission, reflection, and frequency response cal arrays (both broadband and narrowband). This function provides a way to examine the uncorrected performance of the hardware in the analyzer.



Detect Cal ON off: Allows you to switch OFF the power cal for both the internal and external broadband detectors.

View Array Master: Selects the master (uninterpolated) cal arrays from the master to be displayed. These are the cal arrays from the currently active calibration (default, full band, or user-defined).

View Array Interpol: Selects the interpolated cal arrays from the master to be displayed. These are the cal arrays from the currently active calibration (default, full band, or user-defined). If the frequency range of the analyzer has not been changed since the last calibration was performed, then this is the same as the master).

Analog Bus Menu

The analyzer has an analog bus that can be used to troubleshoot hardware problems on some of the boards in the analyzer. This is done by sampling analog bus nodes, which provide measurements at selected points on the boards. Nominal values for each node are provided in Table 5-4.

Select Node: Allows you to select an analog bus node to be measured. The currently selected node description and number are displayed. A node may be selected by using the keypad to enter the number, or by using the front-panel knob or the / keys to scroll through the list.

Sample: Triggers a data measurement of the selected analog bus node.

Table 5-4. Analog Bus Nodes

Number	Name	Description
A4 Source Assembly Nodes		
1	+47V (for HP 8711B/12B) +22V (for HP 8713B/14B)	Source assembly power supply. Nominal value: +44V to +50V (HP 8711B/12B) +20V to +24V (HP 8713B/14B)
2	VCO RF 1 Tune	VCO tuning voltage for the RF1 phase lock loop on the source board (RF1_TUNE on the schematic). Typical values are 7 to 11 volts. A value higher than about 11.5V may indicate a saturated op amp or bad VCO.
3	LO Integrator	Output of integrator in the source LO loop (LO_INT on the schematic). Voltage decreases as source frequency increases. For the 8711B/12B the voltage decreases about 9 volts over the frequency range. For the HP 8713B/14B the voltage decreases about 7 volts over a .3 to 1910 MHz range; voltage shifts at about 1910 MHz.
4	VCO Offset Tune	VCO tuning voltage for the RF2 phase lock loop on the source board (OFFSET_TUNE on the schematic). Value varies with the source frequency setting. Normal values are 6 to 10 volts. A value higher than about 11.5V may indicate a saturated op amp.
5	Output Amp Temp	Shows the temperature at the output amplifier on the source board (OUTPUT_AMP_TEMP on the schematic). Normal values are 30 to 45 degrees Celsius. Not available on the HP 8713B/14B.
6	ALC Log Amp	ALC log amp output on the source board (ALC_LOG on the schematic). Value depends on the source power level. Normal values are -1.75 to -0.5 volts.
7	ALC PIN modulator	Voltage to ALC PIN modulator on the source board. This value increases as the source power increases. Normal values range from 3.0 to 10.5 volts.
A5 Receiver Assembly Nodes		
8	+5V on RCVR	+5V power supply on the receiver board. Normal values are 4.5 to 5.5 volts.
9	+15V on RCVR	+15V power supply on the receiver board. Normal values are 13.5 to 16.5 volts.
10	-15V on RCVR	-15V power supply on the receiver board. Normal values are -16.5 to -13.5 volts.
11	X Det Temperature	X detector temperature (ITEMPX on the receiver schematic). A typical value is 30 degrees Celsius when a detector is connected. If no detector is connected, the typical value is around 0° Celsius.
12	Y Det Temperature	Y detector temperature (ITEMPY on the receiver schematic). A typical value is 30° Celsius when a detector is connected. If no detector is connected, the typical value is around 0° Celsius.
13	B*/Y Autozero	Offset used for the B chopper on the receiver board (BOFFSET on the schematic). Typical values are -12 to +12 volts.
14	R*/X Autozero	Offset used for the R chopper on the receiver board (ROFFSET on the schematic). Typical values are -12 to +12 volts.
15	B* Detector Temp	Temperature of B* internal detector on the receiver board (BTEMP on the schematic). Typical values are 20 to 60° Celsius; this will depend on the ambient temperature. Not available on HP 8713B/14B.

Table 5-4. Analog Bus Nodes (continued)

Number	Name	Description
A2 CPU Assembly Nodes		
16	+5V on CPU	+5V power supply on the CPU board. Normal values are 4.5 to 5.5 volts.
17	+12V Flash Voltage	+12V Vpp supply for writing to the flash EPROM on the CPU board. This voltage is normally OFF, so the value should be less than 2.5V. The "on" voltage level is checked during the power-up tests, and an error message is displayed if the level is incorrect.
18	CPU Temp	Temperature sensor on CPU board (CPU_TEMP on the schematic). Typical values are 30 to 60° Celsius; this will depend partly on the ambient temperature.

More SVC Utilities Menu

ALC DAC: Allows manual adjustment of the Automatic Level Control (ALC) DAC, which controls the source output ("RF OUT" connector) power level. Disables the ALC power calibration until a power level is entered using the Power menu.

Attenuator: Allows manual control of the step attenuator, if one is installed.

LO Power Adjust: Allows manual adjustment of the DAC which controls the LO output power. The LO DAC is used by the HP 8711B/12B receiver board only.

Detector Zero DACs: FOR FACTORY USE ONLY.

Ext Det Info: FOR FACTORY USE ONLY.

Bandcross ON off: FOR FACTORY USE ONLY

View Array Master Menu/View Array Interpol Menu

These keys allow you to view the actual calibration data arrays that are currently in use. The arrays are copied into a memory trace for easy analysis. This allows you to scale them, and use markers to read out actual values.

Note All calibrations are 801 points.

Directivity: Displays the directivity cal array as a memory trace. This is related to the raw directivity of the analyzer but it does not equal it. The raw directivity is determined by dividing the tracking array below by this directivity array.

Source Match: Displays the source match cal array as a memory trace. This is the raw source match of PORT 1.

Tracking: Displays the tracking (narrowband frequency response of coupler with 100% reflection) cal array as a memory trace.

Narrowband Response: Displays the narrowband transmission frequency response cal array as a memory trace.

R* Freq Response: Displays the broadband R* frequency response cal array as a memory trace.

Preset: Presets the analyzer.

Miscellaneous Service Functions

Clearing Nonvolatile Memory (SRAM)

This is also referred to as “zeroing” the nonvolatile SRAM, because the procedure causes the analyzer to write zeroes into the nonvolatile SRAM locations in memory. Note that this will erase any files saved to internal memory (NON-VOL RAM disk).

To clear the memory, switch ON the analyzer’s line power. While the analyzer is running through its self-tests, press the **PRESET** key a few times. The analyzer will finish the main CPU tests, then pause with a message asking if you want to zero the SRAM. Press the **BEGIN** key to clear the memory. Press softkey #8 (bottom softkey) if you want to continue without clearing the memory.

HP-IB Command Reference for Service

Some of the service menu keys have equivalent remote HP-IB commands. The analyzer uses the SCPI programming language. For more information about SCPI and HP-IB, refer to the “HP-IB Programming” section of the *Programming Guide*. Service-related SCPI commands are listed in the following sections.

Syntax Summary

The following conventions are used when SCPI commands are being described:

- Angle brackets (< >) are used to enclose required parameters within a command or query. The definition of the variable is usually explained in the accompanying text.
- Square brackets ([]) are used to enclose implied or optional parameters within a command or query.
- UPPERlower case characters are used to indicate the short form (upper-case) of a given mnemonic. The remaining (lower-case) letters are the rest of the long form mnemonic. Either the short form or the long form may be used.

Softkey SCPI Commands

This section lists the service menu keys in the order they appear on the menu map. See Figure 5-1. Each softkey is shown with its corresponding short-form SCPI command.

Some SCPI commands do not correspond directly to a softkey. These are listed in the alphabetical command summary in Table 5-6, which also lists the long form of each SCPI command.

Table 5-5. Softkey SCPI Commands

Keystrokes	SCPI Command
Tests and Adjustments Menu	
Select Self-Test	TEST:SEL <num>
Select Adjustment	TEST:SEL <num>
Execute Test	TEST:STAT RUN
Stop Test	TEST:STAT STOP
Meas Cal Options Menu	
Meas Cal ON off	SENS[1 2]:CORR[:STAT] <ON1 OFF 0>
Update Corr Const Menu	
Store CC to Disk	DIAG:CCON:STOR:DISK
Store CC to EPROM	DIAG:CCON:STOR:EEPR
Load CC from Disk	DIAG:CCON:LOAD

Alphabetical SCPI Command Summary

This section contains the service-related HP-IB mnemonics recognized by the analyzer with a short description of each command. All commands have a query form unless specified in the “Form” column as command only or query only. To change a command into a query, add a “?”.

The “Form” column also gives the parameter type returned by the analyzer in response to a query. NR1 (integers), NR2 (floating point numbers with explicit decimal point), and NR3 (floating point number in scientific notation) refer to different types of numeric data. CHAR (character data) and STRING (string data, enclosed in quotes) are also used to describe response types. These parameter types are described in the “SCPI Command Summary” section in the *Programmer’s Guide*.

Table 5-6. Alphabetical SCPI Command Summary

Command	Form	Description
DIAGnostic:CCONstants:LOAD	Command	Load correction constants from internal disk drive.
DIAGnostic:CCONstants:STORe:DISK	Command	Store correction constant data to a file on the internal disk drive.
DIAGnostic:CCONstants:STORe:EEPROM	Command	Store correction constant data from the RAM buffer into flash EPROM.
DIAGnostic:CPU:MEMory[:WORD]<addr num> <data num>	NR1	Write a 16-bit data value to a 68020 address. Query returns an integer with the 16-bit value at the selected address.
DIAGnostic:SNUMber <string>	STRING	Store a serial number into memory. The string must be 10 characters long. The query form returns the current serial number.
*IDN?	Query STRING	Return a string that uniquely identifies the analyzer, including model number, serial number, and firmware revision.
*OPT?	Query STRING	Return a string identifying the installed options, in the form “1E1, 1C2”.
SENSe[1 2]:CORRection[:STATe] <ON1 OFF0>	NR1	Switch measurement calibration ON or OFF.
TEST:RESult?	Query CHAR	Query the result of the selected adjustment or self-test. Response will be NULL PASS FAIL.
TEST:SELeCt <num>	NR1	Select the adjustment or self-test to execute.
TEST:STATe <string>	CHAR	Select the state of the active adjustment or self-test. Choose from RUN CONTInue STOP. Query response will be NULL PAUS DONE.
TEST:VALue <num>	NR1	Set or query a value for an adjustment or self-test.
*TST?	Query NR1	Returns the result of a complete self test. An ASCII 0 (zero) indicates no failures found. Any other character indicates a failure.

Theory of Operation

Introduction

This theory of operation begins with a general description of the operation of a network analyzer system. This is followed by more detailed operating theory for the analyzer in particular, divided into functional groups. The operation of each group is described briefly, to the assembly level only. Detailed component-level circuit theory is not provided here.

Simplified block diagrams illustrate the operation of each functional group. A more detailed overall block diagram is provided at the end of the “Troubleshooting and Block Diagrams” chapter.

System Theory

A network analyzer system consists of a source, signal separation devices, a receiver, and a display. The analyzer integrates a synthesized RF source with built-in couplers for signal separation, a combination narrowband and broadband receiver, and a display. Figure 6-1 shows a simplified system block diagram for the analyzer.

In the analyzer, the A3 fractional-N/reference and A4 source assemblies provide the synthesized RF source output. The A5 receiver assembly separates the signals into reference, reflected, and transmitted signals. These inputs are processed as either narrowband or broadband signals. They are then multiplexed into ADCs (analog to digital converters) where they are converted into digital signals. The digital data is processed by the A2 CPU assembly and sent to the A7 display.

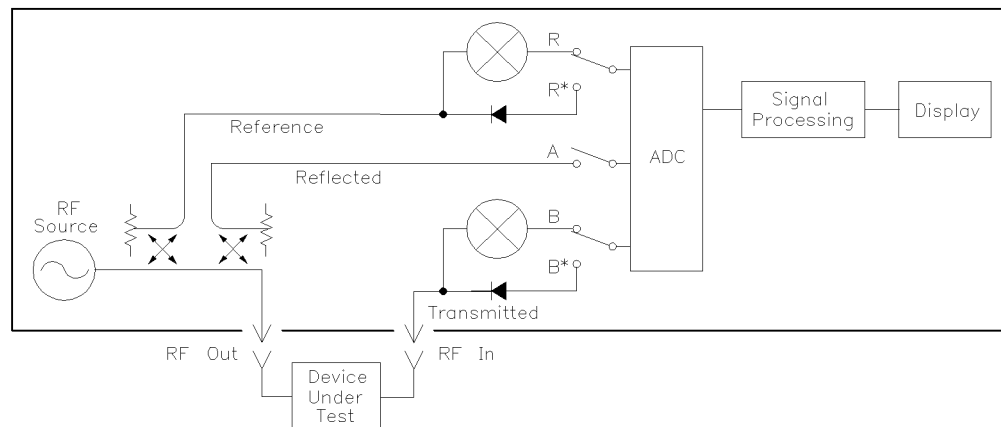

s d62b

Figure 6-1. Simplified Analyzer System Block Diagram

Analyzer Functional Group

Each functional group consists of one or more assemblies that perform one of the basic instrument functions. These groups are the power supply, digital control, source, and receiver.

Power Supply Theory

The power supply group consists of the A6 power supply assembly. This switching power supply provides regulated DC voltages to power all assemblies in the analyzer through a connection to the backplane. The backplane serves as a motherboard to provide power, data, and control signal connections to the various assemblies.

A voltage selector switch, accessible at the rear panel, adapts the analyzer to local line voltages of approximately 115V or 220V nominal. Refer to “Installing the Analyzer” in your analyzer’s *User’s Guide* for line voltage tolerances and other power considerations.

The power supply has a standby state instead of an off state when the AC power is connected. In standby, the A6 assembly provides a standby supply, measuring between +12V and +13V, to power the non-volatile SRAM on the CPU board. (A battery provides power to the non-volatile SRAM when the instrument is disconnected from AC power.) The power supply switches on when the on/standby switch is grounded. In the on state, the power supply provides the following supplies to the instrument: +5V, +15V, –15V, and +12V.

Two diagnostic LEDs are visible from the rear panel. The green LED is on in normal operation. It is off when the line power is absent or set too low, or if the line fuse has blown. The red LED is on in standby but off during normal operation. It will blink to indicate a power supply shutdown. Refer to the “Troubleshooting and Block Diagrams” chapter for more details.

Digital Control Theory

This group includes the A1 front panel, A2 CPU, A7 display, and A8 3.5” internal disk drive assemblies.

A1 Front Panel Assembly

The A1 front panel assembly allows the user to control the analyzer. It includes a keyboard and RPG knob. A probe power jack that supplies +15V and –12.6V is available for use with RF probes and other accessories. Fuses for these supplies are on the back of the A1 front panel assembly PC board.

A2 CPU Assembly

The A2 CPU assembly provides most of the control, interface, and data processing functions in the analyzer. It contains several microprocessors and many different types of memory, as shown on the analyzer’s overall block diagram.

The main CPU is an MC 68020 microprocessor. It is the master controller for the analyzer, including the other dedicated processors on the CPU assembly. When the analyzer is the system controller in an HP-IB system, it also controls peripheral devices through the HP-IB interface.

The TMS 320C25 digital signal processor (DSP) receives the digital data from the A5 receiver assembly and performs data processing functions such as digital filtering, averaging, and applying error correction. It has some dedicated SRAM for running its firmware, and it also uses some shared DRAM and SRAM which is used to transfer data with the CPU.

The TMS 34010 graphics system processor (GSP) is responsible for converting data from the CPU into video signals to drive the A7 display assembly. It also produces an external video output which is accessible from the rear panel.

A number of processors on the CPU assembly allow the analyzer to interface with the outside world. The front panel processor handles inputs from the front panel keyboard and RPG. The floppy disk controller controls the 3.5" internal disk drive. The DIN keyboard interface allows you to connect an external keyboard, which is very useful when writing programs with IBASIC. The Centronics and RS-232 interfaces allow the analyzer to control printers and plotters with a parallel or serial interface. The HP-IB interface allows the analyzer to be a system controller or talker/listener on an HP-IB bus. In addition, there are two TTL outputs (user bit and limit test pass/fail bit) that can be accessed. There is also an external trigger input for sweep control.

The firmware for the analyzer is stored in two places. A bootROM contains low-level firmware that allows the analyzer to run some power-on self-tests, and perform functions such as loading firmware from a disk. The main firmware, which includes the analyzer's operating system and additional self-tests, is stored in EPROMs, along with the correction constant data for the instrument. Both the bootROM and the main EPROMs are flash EPROMs. They can be erased and reprogrammed without removing the CPU assembly from the analyzer. However, erasing the EPROMs for a firmware update also erases the correction constant data, so it is necessary to have a copy of this data on disk for retrieval after the update. The non-volatile SRAM is used to store instrument-state and peripheral-state settings. It is also used as a RAM disk by the save/recall functions, which refer to the non-volatile SRAM as "NON-VOL RAM DISK." This non-volatile SRAM is powered by a +12V to +13V supply when the analyzer is in standby, and by a battery when the AC power is disconnected.

The CPU assembly can also contain SIMM DRAM. This SIMM DRAM can be used in addition to the main DRAM for volatile storage of data and for use by IBASIC programs. No SIMMs are installed at the factory nor are they needed for normal operation.

A7 Display Assembly

The A7 display includes a monochrome 20.8-cm (9-inch) CRT and a matching driver board. Video signals are produced by the A2 CPU assembly and sent to the A7 assembly for display on the CRT. An intensity adjustment is accessible from the front panel. The horizontal scan rate is 24.1 kHz.

A8 3.5" Internal Disk Drive Assembly

The A8 3.5" internal disk drive is referred to by the analyzer as the internal disk. It accepts double density or high density 3.5-inch disks. It can read from or write to either LIF or DOS format disks. The save/recall menus in the analyzer can only format disks in DOS format. However, you can use an external controller or IBASIC (option 1C2) to format disks in LIF format if desired.

Source Theory

The source group consists of the A3 fractional-N/reference assembly and the A4 source assembly.

A3 Fractional-N/Reference Assembly

The A3 fractional-N/reference assembly consists of two boards connected together. The reference board generates the various reference signals used in the analyzer, while the fractional-N assembly generates a 30 to 60 MHz synthesized signal for use in the A4 source assembly.

The reference board uses either the internal 10 MHz crystal oscillator or an external 10 MHz reference signal to generate three reference signals. The 100 kHz signal is used in the fractional-N VCO phase lock loop. The 10 MHz signal is used by the A4 source assembly. A 5 MHz signal goes to the backplane, where it is routed to the A2 CPU and A5 receiver assemblies for use in signal processing.

The fractional-N board is the synthesizer for the source. The 30 to 60 MHz fractional-N VCO output is used for phase-locking the source LO signal, which in turn is used to generate the source RF output.

A4 Source Assembly

The source assembly provides two output signals. One signal, which covers the 0.3 to 1300 (or 3000 MHz for HP 8713B/14B) range, is the main source RF output signal. It goes to the A5 receiver assembly and through an optional AM delay modulator and/or step attenuator before it gets to the RF OUT (REFLECTION) port on the front panel. The other signal serves as the internal receiver LO for downconverting narrowband signals. The two signals are independently phase-locked, and they are separated from one another by the receiver IF (intermediate frequency) of 27.778 kHz.

Note The following paragraphs describe an HP 8711B/12B. The HP 8713B/14B is very similar. See the section “Differences Between the HP 8711B/12B and HP 8713B/14B (1300 MHz vs 3000 MHz)” at the end of this chapter.

These two signals are generated from 3 phase-locked VCOs, as shown in Figure 6-2. In normal operation, the RF1 VCO is phase-locked to a 1 MHz reference signal to produce a stationary 2340 MHz signal. (The 1 MHz signal is derived from the 10 MHz output of the A3 fractional-N/reference assembly.) Similarly, the RF2 VCO is also phase locked to the 1 MHz reference to produce a stationary signal that is offset from RF1 by the receiver IF of 27.778 kHz. The source LO VCO supplies the LO drive for the two source mixers. It covers a 2340.3 to 3640 MHz range. It is phase-locked to a fractional-N sweeping synthesizer (on the A3 fractional-N/reference assembly). As this phase lock loop sweeps, the main source RF output is generated as the mixing product of the 2340 MHz RF1 signal and the sweeping 2340.3 to 3640 MHz source LO signal. Similarly, the receiver LO output is generated by the RF2 signal mixing with the sweeping source LO, resulting in a signal that is offset from the source RF output by the receiver IF.

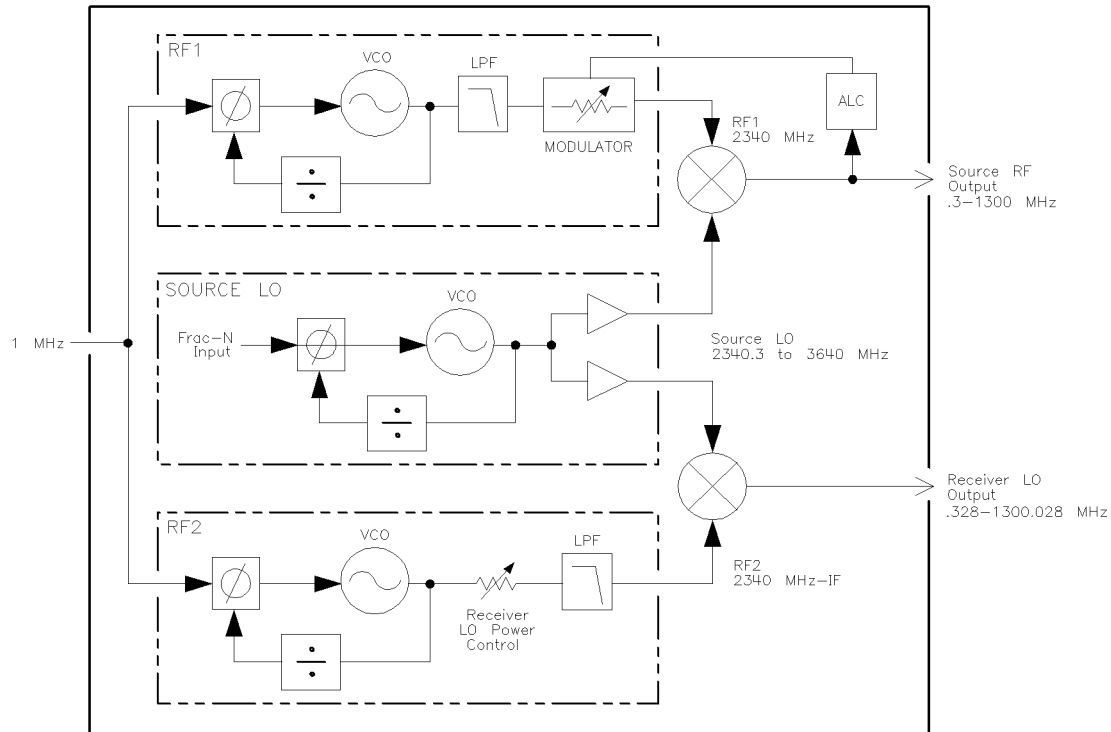

sd63b

Figure 6-2. Simplified HP 8711B/12B A4 Source Block Diagram

Power level control of the source RF output is achieved by using a coupler/detector on the source RF output signal, which controls a modulator on the RF1 signal. Digital correction is applied to the RF2 signal to control the receiver LO power level. Both power levels can be adjusted by running the appropriate service tests. See the “Adjustments” chapter of this guide for more details. The source also has a “dither” mode for spur avoidance. When dither is on, the RF1 frequency changes from 2340 MHz to 2304 MHz, and the RF2 frequency changes to (2304 MHz + IF) to maintain the 27.778 kHz offset between these two signals. Because of these changes, the mixing products from the two source mixers will be at different frequencies, resulting in spurs that have shifted in frequency when compared to the dither off state. This is used in two ways. You can select **Dither ON** (under the SOURCE **(MENU)** key), which causes the analyzer to shift the RF1 and RF2 frequencies to the “dither on” values for all subsequent sweeps, until dither is switched OFF again. This is useful if you are only interested in a narrow frequency span. Switching dither ON successfully moves a spur out of the span of interest. You can also select **Spur Avoid ON**. In this case, the analyzer will approach a known spur frequency, switch dither ON until it sweeps past the spur, then switch dither OFF again until it gets to the next spur. This method is more suitable for wider frequency spans, but it slows down the sweep because of the time required to switch dither function ON and OFF.

Receiver Theory

The A5 receiver assembly is responsible for separating and measuring the RF signals and converting these signals into digital data for further processing by the A2 CPU. Figure 6-3 shows a simplified block diagram of the HP 8711B/12B receiver assembly.

Note The following paragraphs describe an HP 8711B/12B. The HP 8713B/14B are very similar. See the section “Differences Between the HP 8711B/12B and HP 8713B/14B (1300 MHz vs 3000 MHz)” at the end of this chapter.

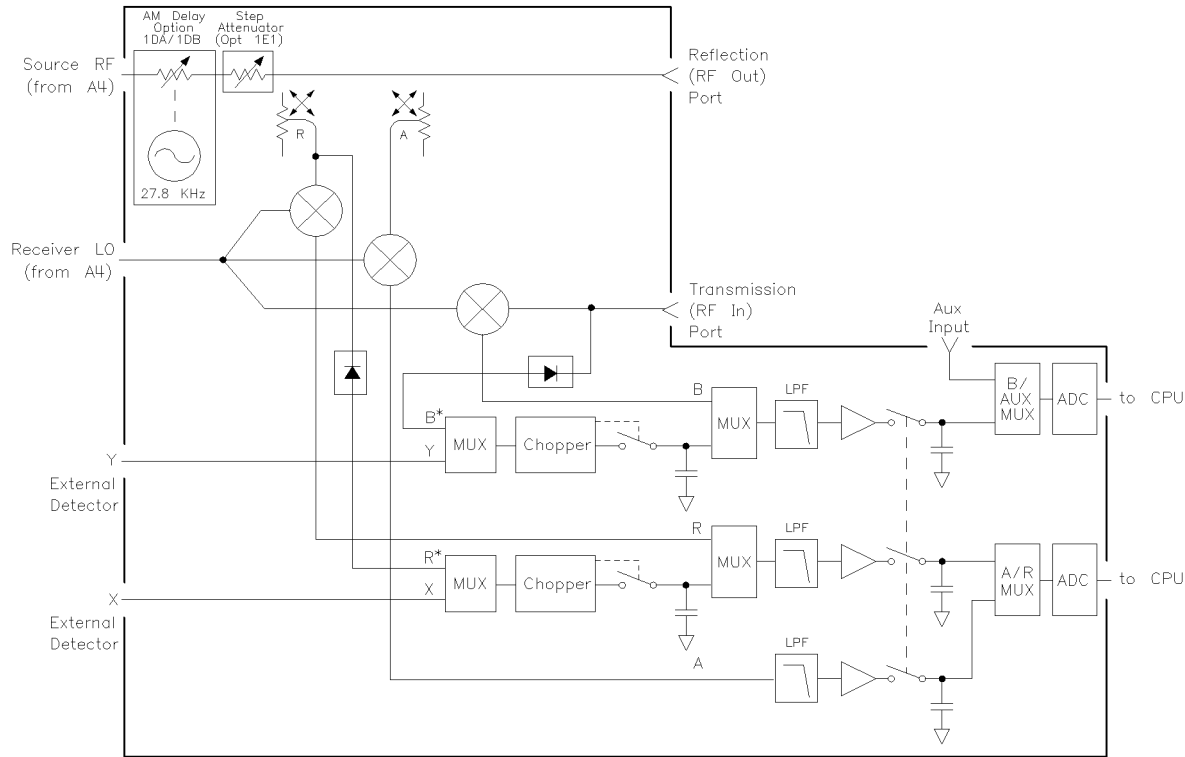

Figure 6-3. Simplified Receiver Block Diagram

The source RF output from the A4 source assembly is input into the receiver. The signal passes through an optional step attenuator and/or AM delay modulator, then through two directional couplers. The first coupler measures the source output signal and uses this as a reference (R input). The source output signal travels through the other arm of the second coupler, which is used in reflection measurements to sample the signal reflected from the REFLECTION test port. This reflected signal is referred to as the A input. The source output signal then goes out the REFLECTION port, propagates through the device under test, and enters the receiver again at the TRANSMISSION or RF IN port. The signal from this port is the B input.

The R, A, and B inputs can be processed in one of two ways. For narrowband measurements, the RF input signal is downconverted to a lower IF frequency of 27.778 kHz using mixers. These mixers are driven by the receiver LO signal from the A4 source assembly. After the signal is downconverted, it is amplified, filtered, and sent to the analog to digital converters (ADCs).

For broadband measurements, the RF input is converted to a DC signal with a diode detector. This DC signal is chopped at a 27.778 kHz rate and then sampled at a rate of 55.5 kHz. This signal is then amplified, filtered, and sent to the ADCs. The analyzer has two internal diode detectors, B* and R*. The A input does not have a broadband detector.

The analyzer can also use one or two external broadband detectors. These detectors convert the measured RF signal into DC signals, which are referred to as the X and Y inputs. The DC inputs are multiplexed into the same choppers used for the B* and R* detectors. The B* and Y inputs share a chopper, and so do R* and X. The signal then follows the same path as the one used for the internal broadband detection.

There is also a rear panel connector for an auxiliary input. This input allows the measurement of DC or low frequency AC signals from -10 to +10 volts.

The analyzer uses adjustment tests to generate correction constant data for all of the internal narrowband and broadband inputs. For the external detectors, the correction constants are stored in an EEPROM in the detector. This data can be read by the receiver to correct the data for the X and Y inputs. There are two 16-bit ADCs on the receiver assembly. The two ADCs are multiplexed between the various narrowband/broadband, internal/external signals. The ADCs require a 2.5 MHz clock signal from the CPU board. They convert the 27.778 kHz signal into digital data, which is then sent to the digital signal processor (DSP) on the A2 CPU board.

Differences Between the HP 8711B/12B and HP 8713B/14B (1300 MHz vs 3000 MHz)

The HP 8713B/14B analyzers are very similar to the HP 8711B/12B. They all share the same front panel, CPU, fractional-N/reference, power supply, display, and firmware. The two major differences are in the source and receiver. Refer to the block diagram of the HP 8713B/14B for an overall view of these two assemblies.

As in the HP 8711B/12B, the source outputs both RF and LO signals that are separated by 27.778 kHz, however the methods used to generate these signals are slightly different. In the receiver, the reflection port coupler has changed significantly. It is a separate dual-directional coupler microcircuit which provides much better accuracy and stability than can be achieved using on-board separate components at 3000 MHz. This also allows the same receiver board to be used for both 50Ω and 75Ω instruments. Only the coupler, a cable, and a jumper setting are different between the two versions.

HP 8713B/14B A4 Source Assembly

The A4 source is designed with four different frequency bands:

- Band 1 = 0.3-1910 MHz
- Band 2 = 1910-2310 MHz
- Band 3 = 2310-2620 MHz
- Band 4 = 2620-3000 MHz

The differences between bands 2, 3, and 4 are only filter changes. Different filters are inserted or removed in the RF and LO signals to minimize spurs. The major change is between bands 1 and 2.

In band 1, below 1.91 GHz, the source is very similar that of the HP 8711B/12B. However, the fractional-N input is first divided by 7 instead of 4, the source LO is divided by 512 instead of 256 and the RF1 signal is 2339.777778 instead of 2340 MHz. This gives a Fractional-N to RF output frequency formula of:

$$RF_{out} = (Fractional-N \times 512/7) - 2339.777778$$

(all frequencies in MHz)

This is very similar to the HP 8711B/12B formula:

$$RF_{out} = (Fractional-N \times 256/4) - 2340$$

The HP 8713B/14B fractional-N input frequency will vary from about 32 to 58 MHz as opposed to the HP 8711B/12B variation of about 36.6 to 57 MHz. In both cases the pulse swallow circuitry maintains the RF2 signal to be 27.778 kHz below the RF1 signal so that the final LO will be 27.778 kHz above the RF, thus generating the proper IF.

In bands 2 through 4, above 1.91 GHz, the RF1 and RF2 signals are divided by 2 to provide an RF1 frequency of 1169.777778 MHz (the ratio is not exactly 1/2 due to differences in the way the pulse swallow circuitry works). The formula for RF output frequency now becomes:

$$RF_{out} = (Fractional-N \times 512/7) - 1169.777778$$

The Fractional-N signal now varies from about 42 to 57 MHz to provide the 1910 to 3000 MHz RF output in bands 2 through 4. This means that during a full band sweep of .3 to 3 GHz, the fractional-N output will first sweep from about 32 to 58 MHz, then reset to 42 MHz, and sweep again up to 57 MHz.

A5 Receiver Assembly

Besides the above mentioned coupler change, there is little functional difference between the HP 8711B/12B receiver and the HP 8713B/14B receiver assemblies. The most significant differences are listed below:

- The coupler is now an external microcircuit with a 16 dB coupling factor.
- Some of the filters have different cutoff/bandpass frequencies.
- Some attenuators have different values.
- A leveling loop is used to maintain proper LO power to the 3 mixers. This eliminates the need for the LO power adjustment (adjustment #101).

Of course, all input components have been modified to perform at 3 GHz, but from a functional point of view, little else is changed from the HP 8711B/12B receiver board.

Parts List

Analyzer Hardware

The HP 8711B/12B/13B/14B analyzer has been designed to have a minimal number of different screw types. Most all applications require one of only two screw types. All are TORX screws requiring a TORX driver (PN= pan head; FL= flat head). Listed below are all the required screws. For clarity, these are not listed on the following parts lists for each assembly.

HP 8711B/12B/13B/14B Analyzer Hardware

Part Number	Description	Where Used (Quantity)	Torque	Driver
0515-0430	M3 x 6 PN	Most places; all sheet metal	7 in-lbs	T10
0515-0664	M3 x 12 PN	All casting shields	7 in-lbs	T10
0515-1946	M3 x 6 FL	Handle nut plate screws (4)	7 in-lbs	T10
0515-0943	M4 x 12 FL	Handle screws (8)	21 in-lbs	T15
0515-0658	M2 x 6 PN	Power switch (2)	3 in-lbs	T6
0515-0374	M3 x 10 PN	Connector, Display Ribbon Cable (2)	7 in-lbs	T10

Note: All semi-rigid coax cables should be tightened to 10 in-lbs.

Specific Assembly and Cable Locations

The following tables and figures describe the replaceable parts for each of the analyzer's major assemblies. For information on ordering replacement parts see "How to Order Parts" in the "Assembly Replacement" chapter.

Table 7-1. HP 8711B/12B Major Assembly and Cable Locations

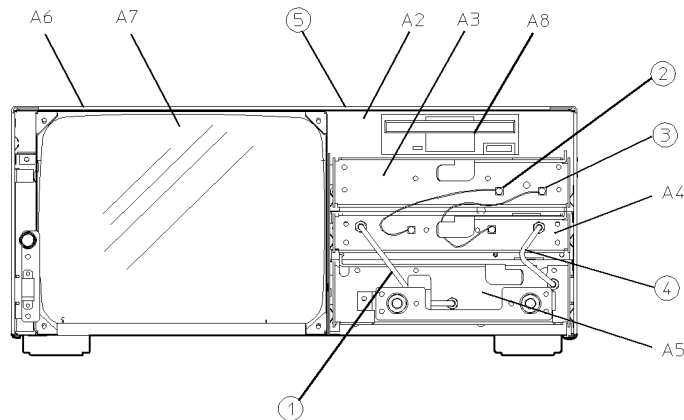

Item	Description	HP Part Number	Quantity
A1	Front panel assembly (removed)	See Table 7-3	1
A2	CPU assembly (not shown)	See Table 7-4	1
A3	Fractional-N/reference assembly	See Table 7-5	1
A4	Source assembly	See Table 7-6	1
A5	Receiver assembly	See Table 7-8 (standard) or Table 7-9 (options 1E1 and/or 1DA/1DB)	1
A6	Power supply (not shown)	See Table 7-12	1
A7	Display assembly	See Table 7-13	1
A8	3.5" internal disk drive (attached to the A2 assembly)	See Table 7-4	1
1	Cable, A4J1 to A5 LO input	08712-20024	1
2	Cable, A4J2 to A3J1	08753-60061	2
3	Cable, A4J3 to A3J3	08753-60061	
4	Cable, A4J4 to A5 RF input	08712-20029	1
5	Backplane cover (not shown)	08712-00002	1

Table 7-2. HP 8713B/14B Major Assembly and Cable Locations

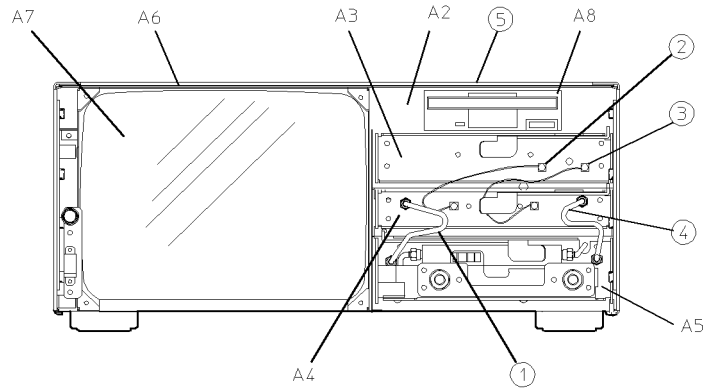

sd647b

Item	Description	HP Part Number	Quantity
A1	Front panel assembly (removed)	See Table 7-3	1
A2	CPU assembly (not shown)	See Table 7-4	1
A3	Fractional-N/reference assembly	See Table 7-5	1
A4	Source assembly	See Table 7-7	1
A5	Receiver assembly	See Table 7-10 (standard) or Table 7-11 (options 1E1 and/or 1DA/1DB)	1
A6	Power supply (not shown)	See Table 7-12	1
A7	Display assembly	See Table 7-13	1
A8	3.5" internal disk drive (attached to the A2 assembly)	See Table 7-4	1
1	Cable, A4J1 to A5 LO input	08713-20022	1
2	Cable, A4J2 to A3J1	08753-60061	1
3	Cable, A4J3 to A3J3	08753-60061	1
4	Cable, A4J4 to A5 RF input	08713-20023	1
5	Backplane cover (not shown)	08712-00002	1

Table 7-3. A1 Front Panel Assembly and Cable Locations

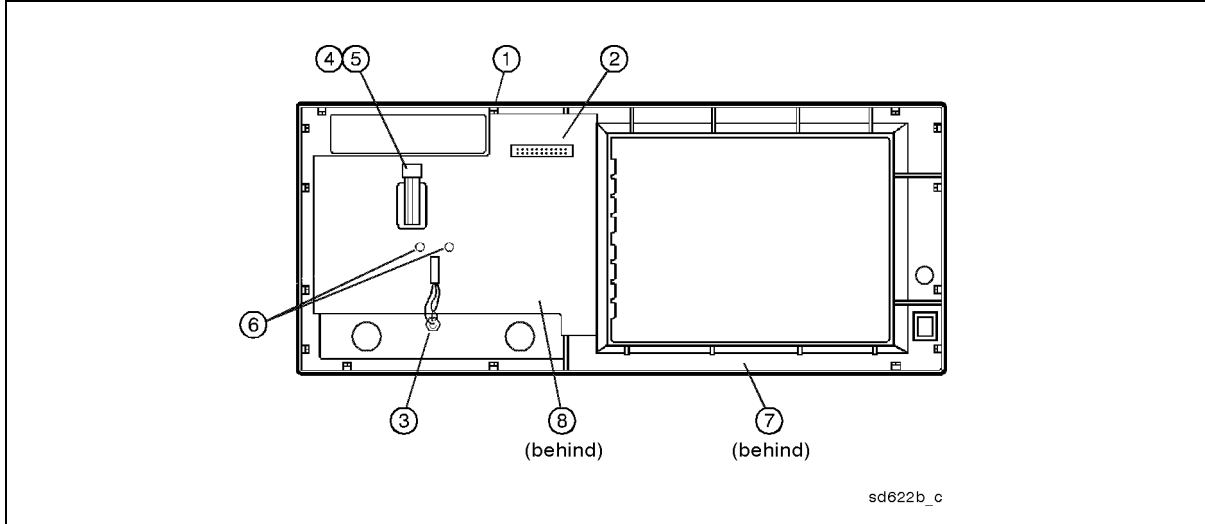

Item	Description	HP Part Number	Quantity
1	Front panel assembly, 50 Ω	08712-60014	1
	Front panel assembly, 75 Ω	08712-60016	1
	Front frame	08711-40001	1
2	Keyboard assembly	08711-60101	1
3	Probe power socket	08711-60037	1
4	RPG (Rotary Pulse Generator) assembly	1990-1525	1
5	Knob (for RPG, on reverse side)	01650-47401	1
6	Fuse for power probe socket, 0.75A, 125V	2110-0424	2
7	Label, HP 8711B	08711-80035	1
	Label, HP 8712B	08712-80003	1
	Label, HP 8713B	08713-80001	1
	Label, HP 8714B	08714-80001	1
8	Panel, front dress, 50 Ω	08711-80002	1
	Panel, front dress, 75 Ω	08711-80004	1

Table 7-4. A2 CPU Assembly and Cable Locations

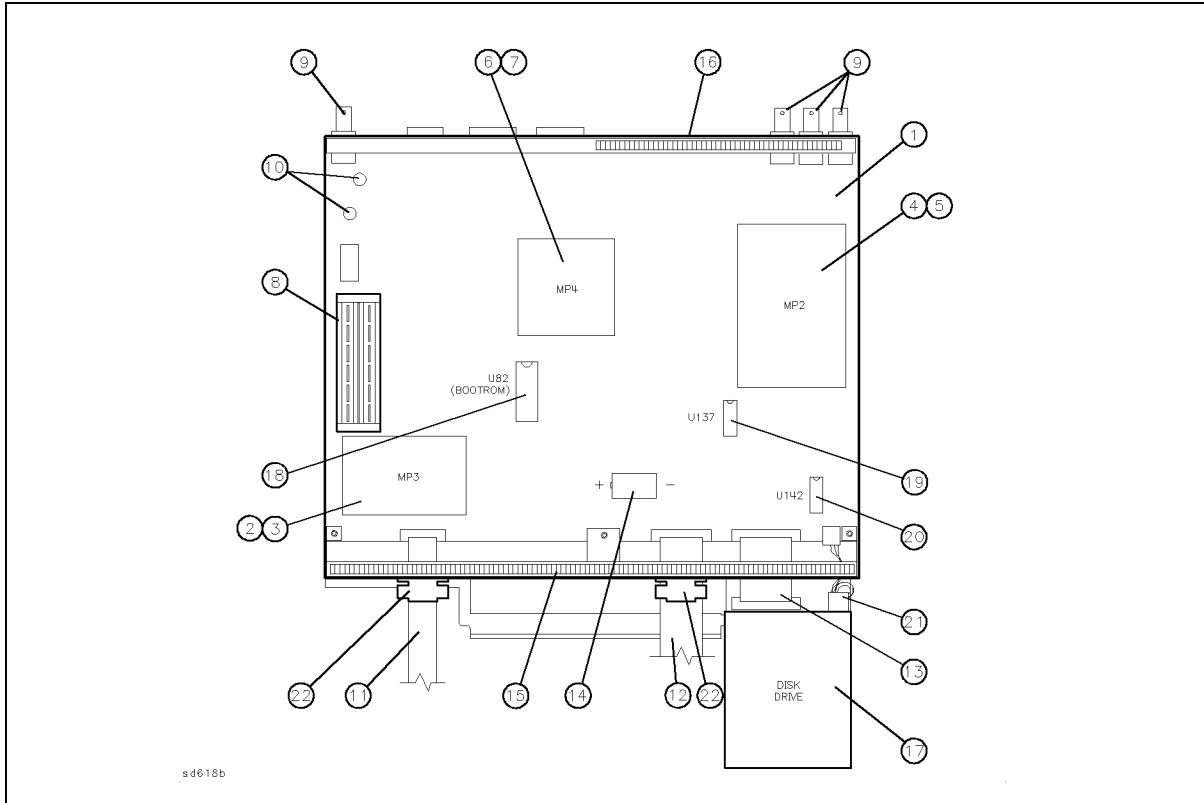

Item	Description	HP Part Number	Quantity
1	A2 CPU assembly (new)	08712-60002	1
	A2 CPU assembly (R-E)	08712-69002	
2	GSP shield (MP3 bottom strip)	08711-20054	1
3	GSP shield (MP3 cover)	08711-20055	1
4	DSP shield (MP2 bottom strip)	08711-20056	1
5	DSP shield (MP2 cover)	08711-20057	1
6	CPU shield (MP4 bottom strip)	08711-20058	1
7	CPU shield (MP4 cover)	08711-20059	1
8	DRAM SIMM socket; (1M×9 SIMM)*	1818-4268	2
9	BNC jacks	1250-1842	4
10	Fuse, DIN interface, 3A 125V	2110-0332	2
11	Cable, ribbon, display assembly	8120-5526	1
12	Cable, ribbon, Front panel assembly	8120-5527	1
13	Cable, ribbon, 3.5" internal disk drive assembly	8120-6474	1
14	Battery, 3.0V	1420-0338	1
15	CPU front shield assembly	08712-60003	1
16	CPU rear shield assembly	08712-00004	1
17	A8 3.5" internal Disk Drive Assembly (NOT part of A2 CPU assembly)	0950-2075	1
18	BootROM U82	†	
19	Option ROM #1 U137	†	
20	Option ROM #2 U142	†	
21	3.5" internal disk drive power cable	08712-60015	1
22	Clamp, ribbon cable	08711-00012	2

*SIMM DRAM must be installed in pairs (2 or 4). Use 1M×9 SIMMs. Do not use SIMMs containing only 3 ICs.
 †Contact your local HP sales and service office.

Table 7-5. A3 Fractional-N/Reference Assembly and Cable Locations

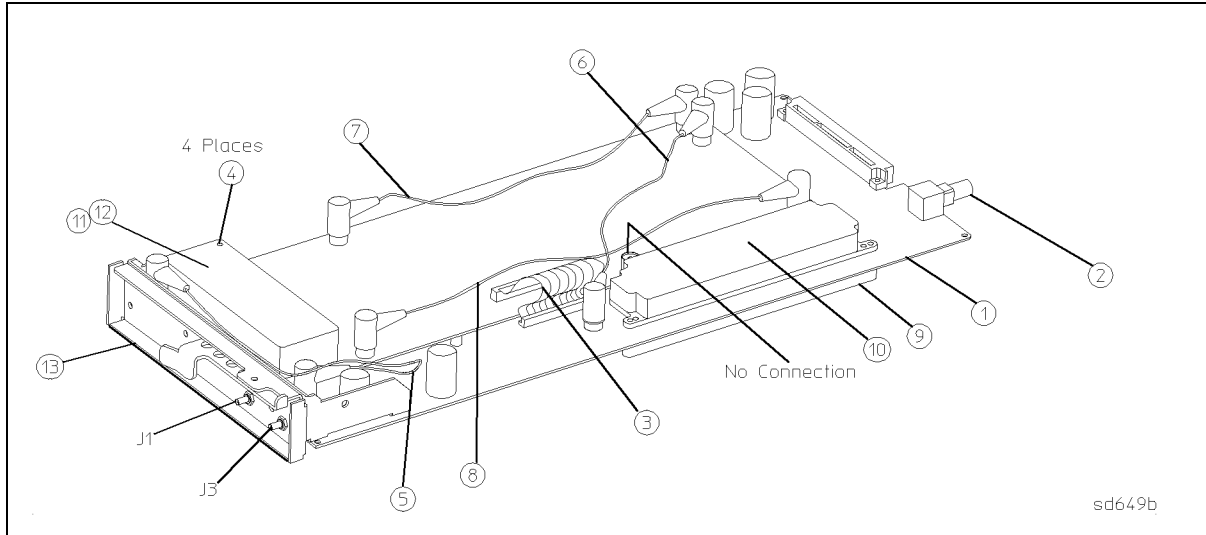

Item	Description	HP Part Number	Quantity
1*	A3 Fractional-N/reference circuit board assembly (new)	08712-60011	1
	A3 Fractional-N/reference circuit board assembly (R-E)	08712-69011	
2	J6 external reference input jack, BNC	1250-1842	1
	Hex nut for BNC jack (not shown)	2950-0054	1
	Washer for BNC jack (not shown)	2190-0068	1
3	Cable, connection, 21C	8120-5494	1
4	Screw, machine, M3 × 35	0515-1038	4
5	Cable, J2 to J15 8.5 in.	8120-2587	1
6	Cable, J4 to J8 8.5 in.	8120-2587	1
7	Cable, J7 to J17 8.5 in.	8120-2587	1
8	Cable, J18 to J18 SH 12 in.	8120-2586	1
9	Shield, REF (bottom)	08711-20021	1
10	Shield, REF (top)	08711-20020	1
11	Shield, fractional-N/VCO (top)	03325-40602	1
12	Shield, fractional-N/VCO (spacer plate)	03325-40601	1
13	Front shield/handle assembly, fractional-N/reference	08712-60008	1
J1	Connector, SMB, fractional-N output	1250-1512	1
J3	Connector, SMB, 10 MHz reference output	1250-1512	1

*Item 1 consists of two circuit boards. Do not take them apart. They must be ordered together with the above part number.

Table 7-6. HP 8711B/12B A4 Source Assembly and Cable Locations

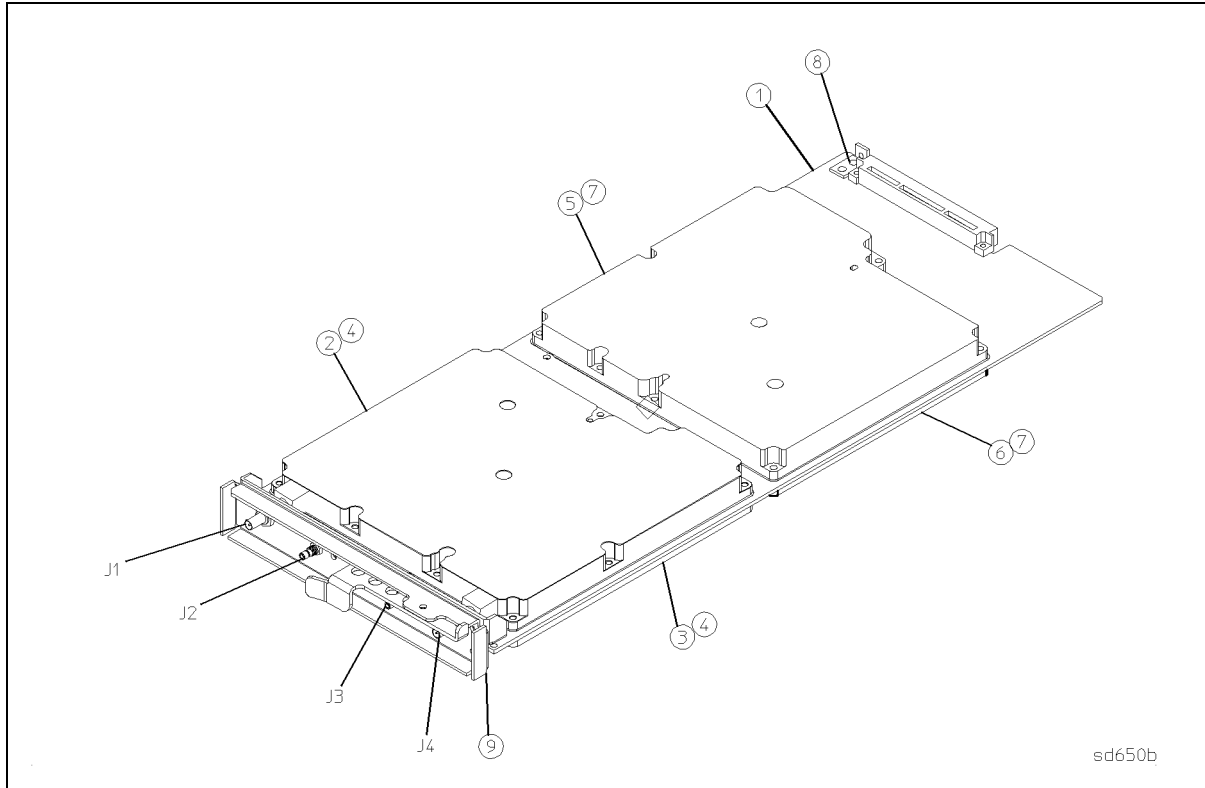

Item	Description	HP Part Number	Quantity
1	A4 Source assembly (new)	08712-60004	1
	A4 Source assembly (R-E)	08712-69004	
2	Front shield (top)	08711-20022	1
3	Front shield (bottom)	08711-20023	1
4	Front shield gasket	08711-20043	2
5	Rear shield (top)	08711-20024	1
6	Rear shield (bottom)	08711-20025	1
7	Rear shield gasket	08711-20044	2
8	L bracket	1400-1669	1
9	Front shield/handle	08712-60007	1
J1, J4	Connector, SMA	1250-1986	2
J2, J3	Connector, SMB	1250-1512	2
	Lockwasher .195 in. (not shown, for SMB)	2190-0124	2
	Nut - Hex 10-32 in. (not shown, for SMB)	2950-0078	2

Table 7-7. HP 8713B/14B A4 Source Assembly and Cable Locations

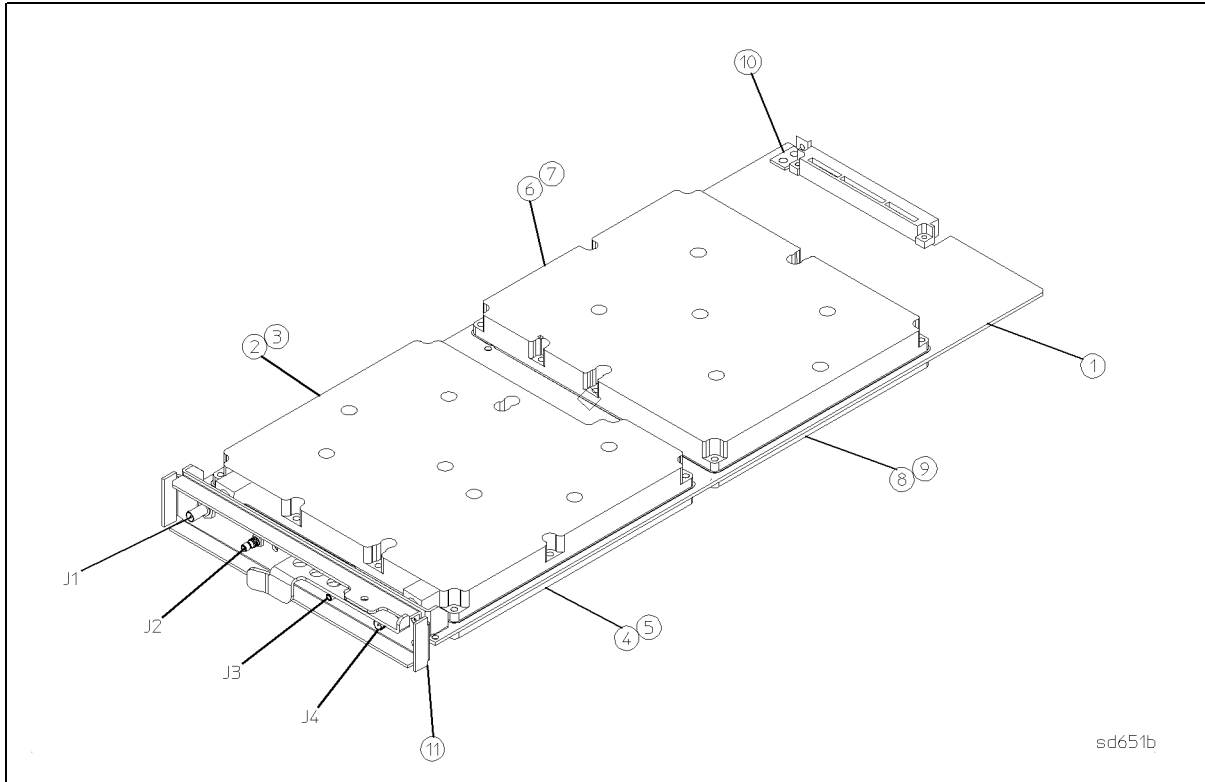

Item	Description	HP Part Number	Quantity
1	A4 Source assembly (new)	08713-60004	1
	A4 Source assembly (R-E)	08713-69004	
2	Front shield (top)	08713-20024	1
3	Front shield gasket (top)	08713-20028	1
4	Front shield (bottom)	08713-20026	1
5	Front shield gasket (bottom)	08713-20030	1
6	Rear shield (top)	08713-20025	1
7	Rear shield gasket (top)	08713-20029	1
8	Rear shield (bottom)	08713-20027	1
9	Rear shield gasket (bottom)	08713-20031	1
10	L bracket	1400-1669	1
11	Front shield/handle	08712-60007	1
J1, J4	Connector, SMA	1250-1986	2
J2, J3	Connector, SMB	1250-1512	2
	Lockwasher .195 in. (not shown, for SMB)	2190-0124	2
	Nut - Hex 10-32 in. (not shown, for SMB)	2950-0078	2

7-8 Parts List

Table 7-8. HP 8711B/12B A5 Receiver Assembly and Cable Locations

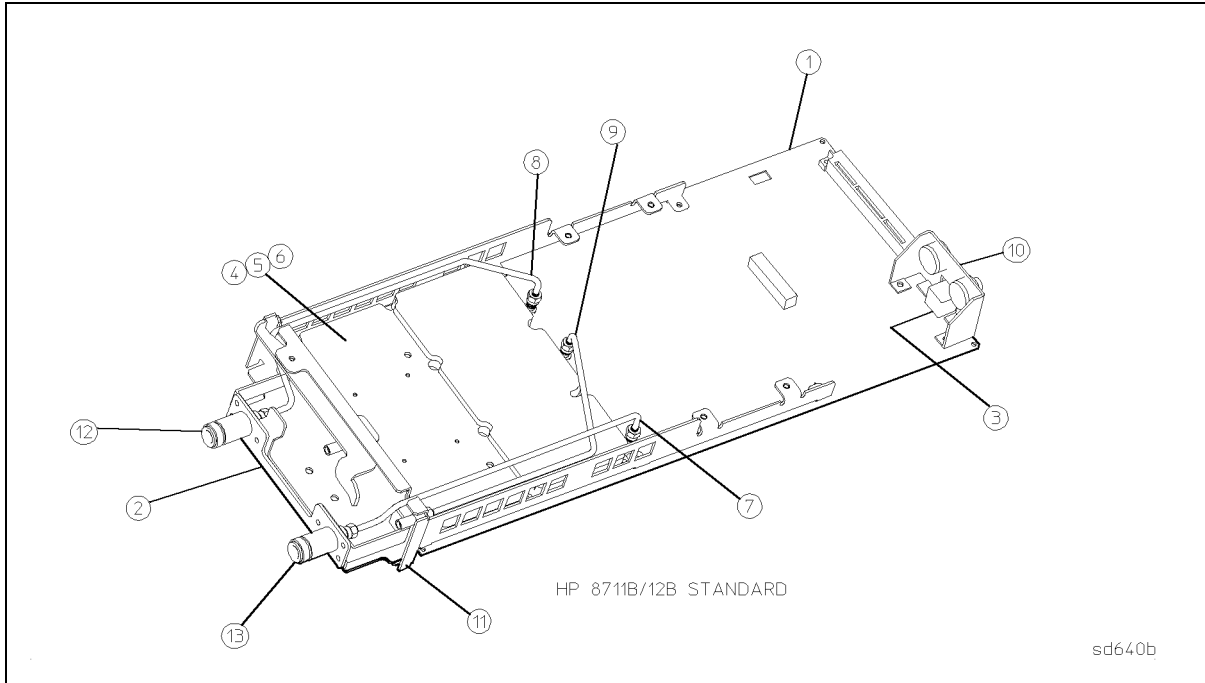

Item	Description	HP Part Number	Quantity
1	A5 receiver assembly (new), 50Ω	08712-60020	1
	A5 receiver assembly (R-E), 50Ω	08712-69020	
	A5 receiver assembly (new), 75Ω	08712-60022	1
	A5 receiver assembly (R-E), 75Ω	08712-69022	
2	Test port assembly, 50Ω (connectors and bracket)	08711-60038	1
	Test port assembly, 75Ω (connectors and bracket)	08711-60039	1
3	Connector, BNC, auxiliary input	1250-1842	1
	Hex nut for BNC connector	2950-0054	1
	Washer for BNC connector	2190-0068	1
4	Square shield (top)	08712-20013	1
	Square shield (bottom)	08711-20026	1
6	Square shield gasket	08711-20040	2
7	Connector, RF IN to J4 cable assembly	08712-20016	1
8	Cable, J2 to RF OUT, 50Ω	08712-20014	1
	Cable, J2 to RF OUT, 75Ω	08712-20028	1
9	Cable assembly, Source RF to J3	08712-20025	1
10	External detector input (includes both inputs, cables, and bracket)	08711-60021	1
11	Front shield	08712-60006	1
12	Connector, RF output, 50Ω	86290-60005	2
	Connector, RF output, 75Ω	08752-60009	1
13	Connector, RF input, 50Ω	86290-60005	1
	Connector, RF input, 75Ω	08752-60010	1

**Table 7-9.
HP 8711B/12B A5 Receiver Optional Configurations Assembly and
Cable Locations**

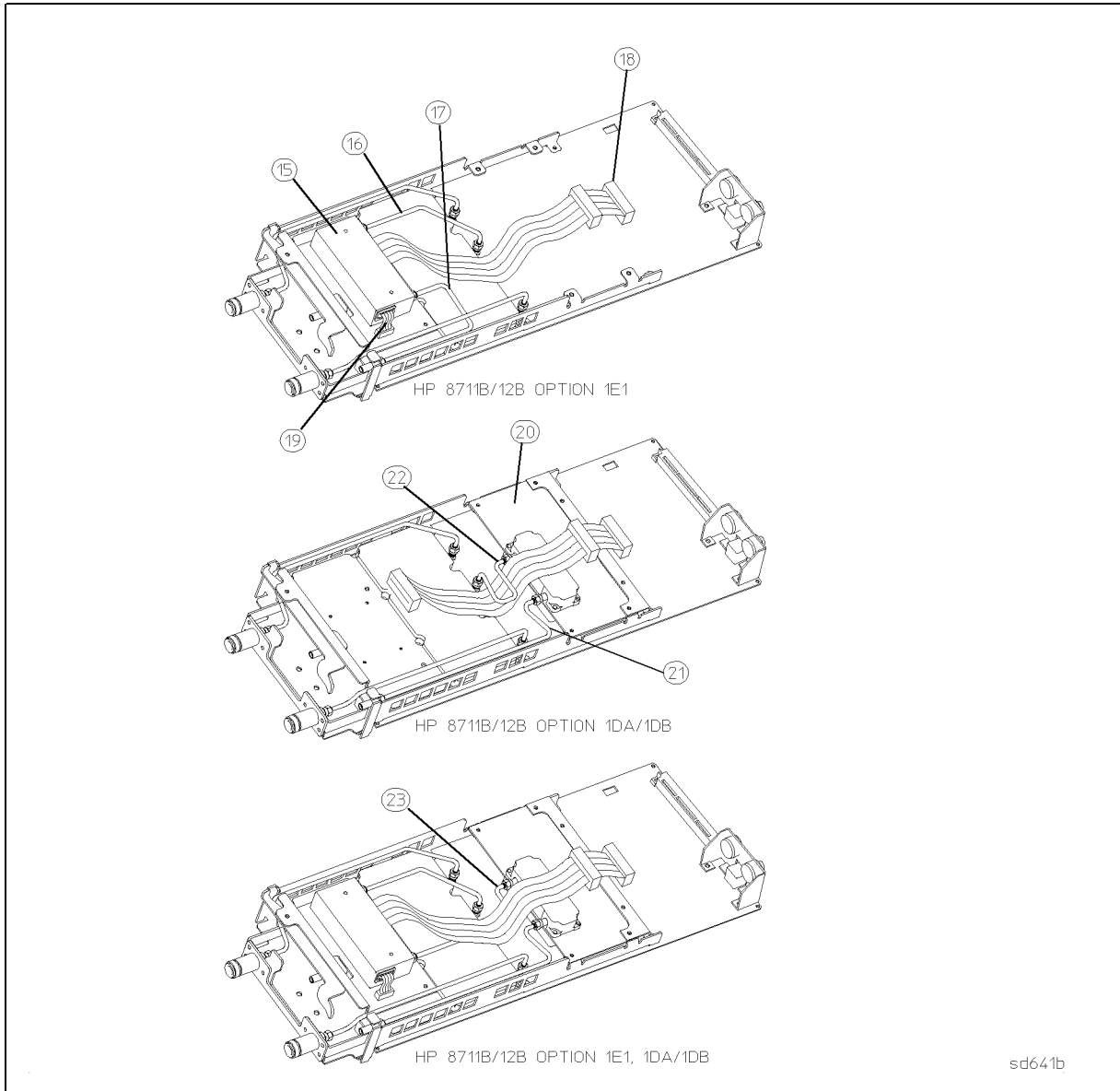

Item	Description	HP Part Number	Quantity
15	Attenuator assembly (board and attenuator)	08712-60023	1
16	Cable, ATTN OUT to J3	08712-20015	1
17	Cable, RF IN to ATTEN IN	08712-20023	1
18	Cable, ribbon, option	8120-6475	1
19	Cable, ribbon, attenuator	8120-6473	1
20	AM delay modulator assembly	08712-60009	1
21	Cable, RF IN to AM DELAY MOD IN	08712-20018	1
22	Cable, AM DELAY MOD OUT to J3	08712-20019	1
23	Cable, AM DELAY MOD OUT to ATTEN IN	08712-20017	1

Table 7-10. HP 8713B/14B A5 Receiver Assembly and Cable Locations

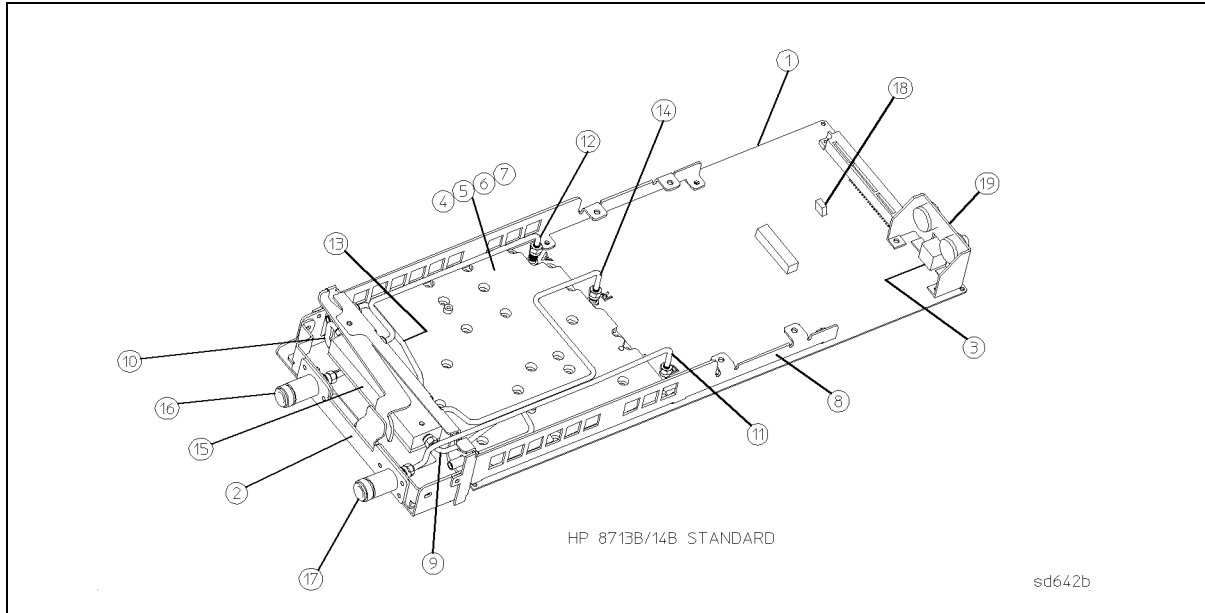

Item	Description	HP Part Number	Quantity
1	A5 Receiver assembly (new), 50Ω	08713-60005	1
	A5 Receiver assembly (R-E), 50Ω	08713-69005	
	A5 Receiver assembly (new), 75Ω	08713-60007	
	A5 Receiver assembly (R-E), 75Ω	08713-69007	
2	Test port assembly, 50Ω (connectors and bracket)	08711-60038	1
	Test port assembly, 75Ω (connectors and bracket)	08711-60039	1
3	Connector ,BNC, auxiliary input	1250-1842	1
	Hex nut for BNC connector	2950-0054	
	Washer for BNC connector	2190-0068	
4	Square shield (top)	08713-20033	1
5	Square shield (bottom)	08713-20034	1
6	Square shield gasket (top)	08713-20035	1
7	Square shield gasket (bottom)	08713-20036	1
8	Front shield	08713-60006	1
9	RF source-coupler IN cable	08713-20019	1
10	Cable, test port, 50Ω	5022-1149	1
	Cable, test port,† 75Ω	5022-1152	1
11	Cable, RF IN J4	08713-20013	1
12	Cable, J3 coupler - A -	08713-20011	1
13	Cable, LO source - J1 -	08713-20010	1
14	Cable, J2 coupler - R -	08713-20012	1
15*	Coupler, 50Ω	5086-7936	1
	Coupler, 75Ω	5086-7937	1
16	Connector, RF output, 50Ω	86290-60005	2
	Connector, RF output, 75Ω†	08752-60009	1
17	Connector, RF input, 50Ω	86290-60005	1
	Connector, RF input, 75Ω	08752-60010	
18	Jumper, option	1258-0141	1
19	External detector input (includes both X and Y input connectors, cables and brackets)	08711-60021	1

*Coupler assembly includes both test port connectors and mounting plate.

† Use extreme caution when connecting this cable. It is very fragile and can be easily damaged.

**Table 7-11.
HP 8713B/14B A5 Receiver Optional Configurations Assembly and
Cable Locations**

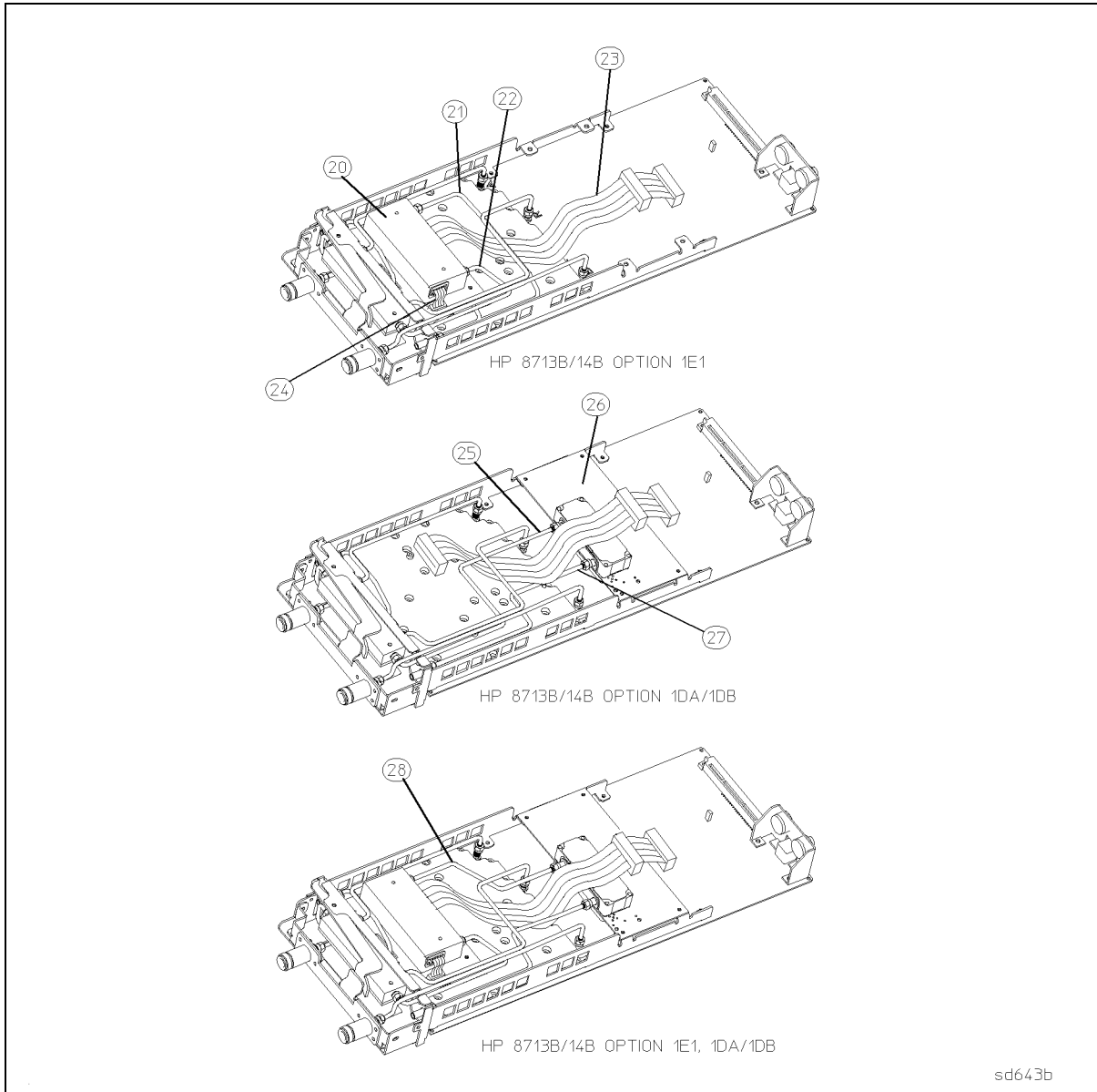

sd643b

Item	Description	HP Part Number	Quantity
20	Attenuator assembly (board and attenuator)	08712-60023	1
21	Cable, RF IN to ATTEN IN	08713-20018	1
22	Cable, ATTEN OUT to COUPLER IN	08713-20016	1
23	Cable, ribbon, options	8120-6475	1
24	Cable, ribbon, attenuator (part of item 19)	8120-6473	1
25	Cable, AM DELAY MOD OUT to COUPLER IN	08713-20021	1
26	AM Delay modulator assembly	08712-60009	1
27	Cable, RF IN to AM DELAY MOD IN	08713-20020	1
28	Cable, AM DELAY MOD OUT to ATTEN IN	08713-20015	1

7.12 Parts List

Table 7-12. A6 Power Supply Assembly and Cable Locations

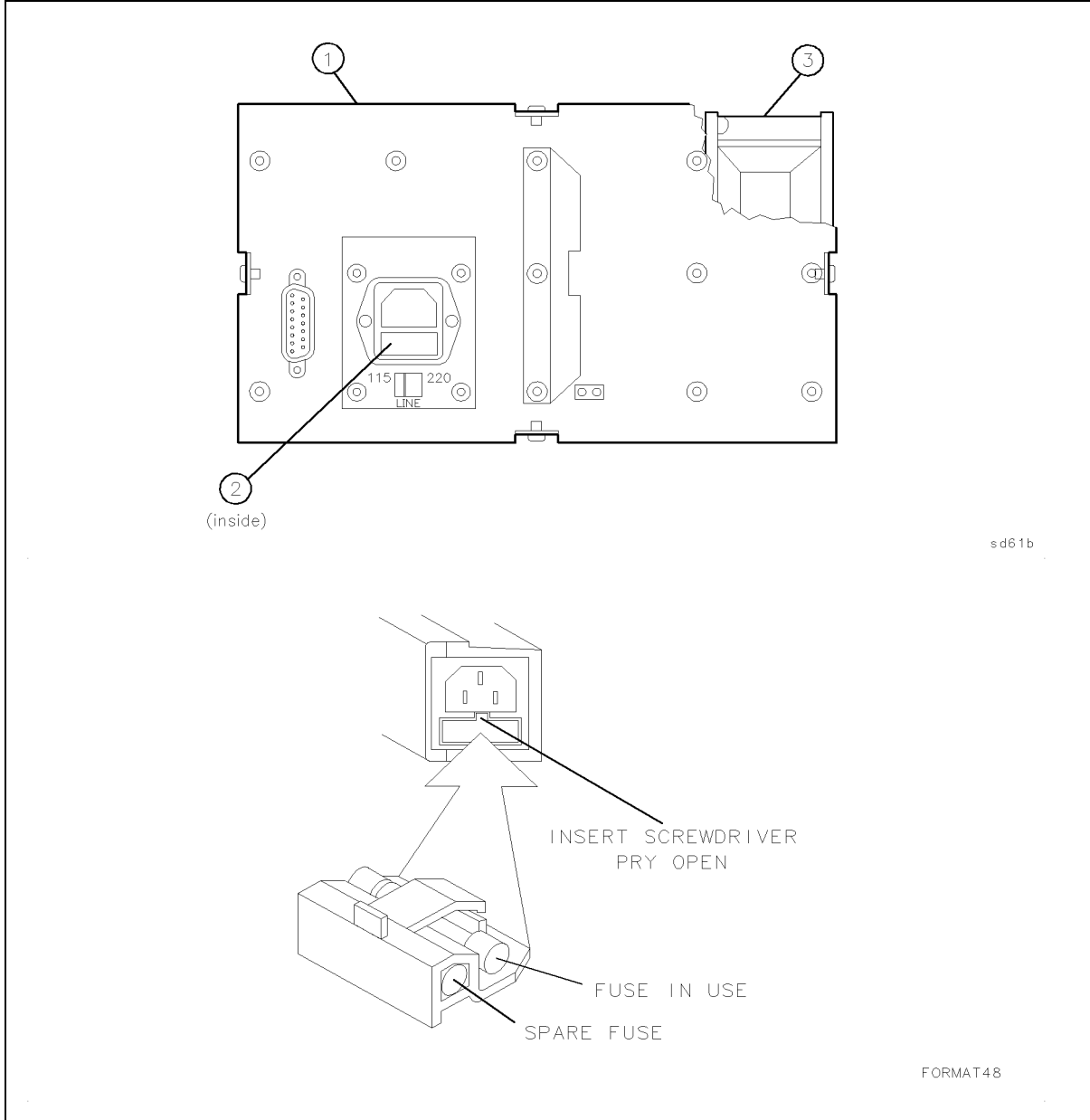

Item	Description	HP Part Number	Quantity
1	A6 power supply assembly (new)	0950-2201	1
	A6 power supply assembly (R-E)	5062-3437	0
2	Fuse, 5A, 250V, time-lag (5 × 20 mm)	2110-0882	2
3	Fan assembly	5062-3412	1

Table 7-13. A7 Display Assembly and Cable Locations

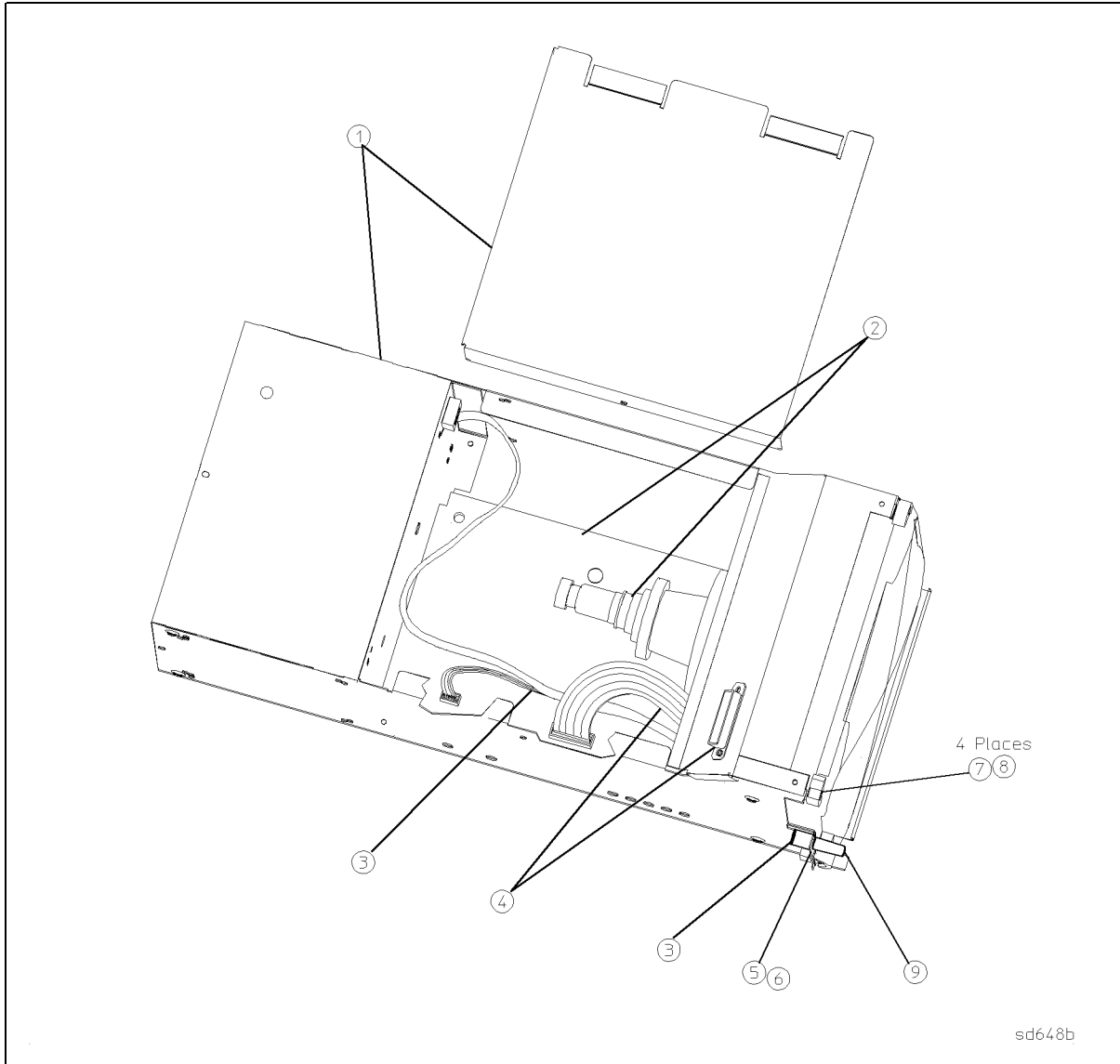

Item	Description	HP Part Number	Quantity
1	Display enclosure	08712-60010	1
2	CRT with board	2090-0319	1
3	Switch, intensity control, and cable assembly	08711-60023	1
4	Cable, display 20C w/headers	8120-5525	1
5	Lock washer .256 in. ID	2190-0067	1
6	Nut 1/4-36	2950-0216	2
7	Washer, Flat .125 in. ID	3050-0116	4
8	Nut M3	0535-0031	4
9	Knob, intensity	08711-40004	1
	Bracket, monitor board (not shown)	08712-00005	1

Table 7-14. Cabinet and Miscellaneous Parts

Description	HP Part Number
CABINET PARTS (Quantity per Analyzer)	
Chassis (includes connector board and labels)	08712-60026
Power cord (varies by country, consult your CE)	
Front handle (2)	5062-3800
Front handle trim (2)	5021-8497
Front handle nut plate (2)	08711-00007
Screws for front handles (8)	0515-0943
Foot (4)	08711-40005
RFI spring strip, 16 in. (cut as required)	8160-0775
Backplane cover	08712-00002
Disassembly label (on bottom of analyzer)	08712-80002
Rear panel label	08712-80001
Rack mount kit (for use with or without handles)	08712-60058
Cabinet color: French Gray	
Fuse, power supply 5A, 250V, time delay, 5 × 20 mm (2)	2110-0882
SOFTWARE	
Performance test program	08712-10011
Example programs disk (LIF format)	08712-10002
Example programs disk (DOS format)	08712-10001
IBASIC Example programs disk	08712-10003
Firmware kit	08712-60013
ACCESSORIES	
50Ω 3.5-mm calibration kit	HP 85033C opt 001
50Ω type-N calibration kit	HP 85032B/E
50Ω 3.5-mm accessory kit	HP 11878A
50Ω type-N accessory kit	HP 11853A
50Ω BNC accessory kit	HP 11854A
50Ω type-N to TNC adapter kit	HP 86212A
50Ω to 75Ω minimum loss pad	HP 11852B
75Ω type-N calibration kit	HP 85036B/E
75Ω type-N accessory kit (adapters, shorts, loads)	HP 11855A
75Ω type-N to 75Ω BNC assembly kit	HP 11856A
75Ω type-N to type-F adapter kit	HP 86211A
24-inch BNC test port cable (50Ω)	HP 8120-1839
50Ω type-N, male-to-male test port cable (precision)	HP 8120-4781
50Ω type-N, male-to-male test port cable (economy)	HP 8120-6469
75Ω type-N, male-to-male test port cable (precision)	HP 8120-2408
75Ω type-N, male-to-male test port cable (economy)	HP 8120-6468
75Ω type-N, male-to-female test port cable (precision)	HP 8120-2409
Power splitter 2-way, 50Ω, 3 GHz	0955-0751
Power splitter 2-way, 75Ω, 3 GHz	0955-0752

Table 7-14. Cabinet and Miscellaneous Parts (continued)

Description	HP Part Number
ACCESSORIES (continued)	
Attenuator, 75Ω, 3 dB	0955-0765
Attenuator, 75Ω, 6 dB	0955-0766
Attenuator, 75Ω, 10 dB	0955-0767
Attenuator, 75Ω, 20 dB	0955-0768
1.0 meter HP-IB cable	HP 10833A
2.0 meter HP-IB cable	HP 10833B
4.0 meter HP-IB cable	HP 10833C
0.5 meter HP-IB cable	HP 10833D
2.0 meter (standard) detector cable	8120-5515
20.0 meter detector cable	8120-5514
Keyboard template	08712-80004
Mini-DIN to DIN adapter	C1405-60015
High frequency probe	HP 85024A
50Ω RF scalar detector	HP 86200B
50Ω RF bridge	HP 86205A
75Ω RF scalar detector	HP 86201B
75Ω RF bridge	HP 86207A
UPGRADE KITS	
Attenuator (opt 1E1) upgrade kit	08711-60067
IBASIC (opt 1C2) upgrade kit	08711-60068
Firmware kit	08712-60013
AM delay kit (does not include detectors or power splitter)	08711-60062
SERVICE TOOLS	
Service tool kit: Extender board assembly Two SMB extension cables, 12 inches long (30 cm) Modified 5/16-inch wrench Non-shielded display ribbon cable 6-inch (150 mm) Semi-rigid coaxial extender cable Voltage reference source	08712-60012
Spare parts kit (includes A2, A3, A4, A5, A8) For HP 8711B/12B, 50Ω For HP 8711B/12B, 75Ω For HP 8713B/14B, 50Ω For HP 8713B/14B, 75Ω	08712-60024 08712-60025 08713-60014 08713-60013
DOCUMENTATION	
HP 8711B/13B manual set	08713-90001
HP 8712B/14B manual set	08712-90001
HP 8711B/13B User's Guide	08713-90003
HP 8712B/14B User's Guide	08712-90003
HP 8711B/12B/13B/14B Service Guide	08713-90005
HP 8711B/12B/13B/14B schematic package (avail 1996)	08712-90007
HP 8711B/12B/13B/14B IBASIC manual set	08712-90005

Correction Constants and Firmware

Storing and Recalling Correction Constants (CC)

Note Because firmware and correction constants reside on flash EPROMs, to update EITHER of them you must first erase the information in ALL of the EPROMs. Therefore, you MUST have a firmware disk available to update correction constants (because you cannot make a firmware disk yourself). The figure below illustrates the flow of correction constants in the analyzer.

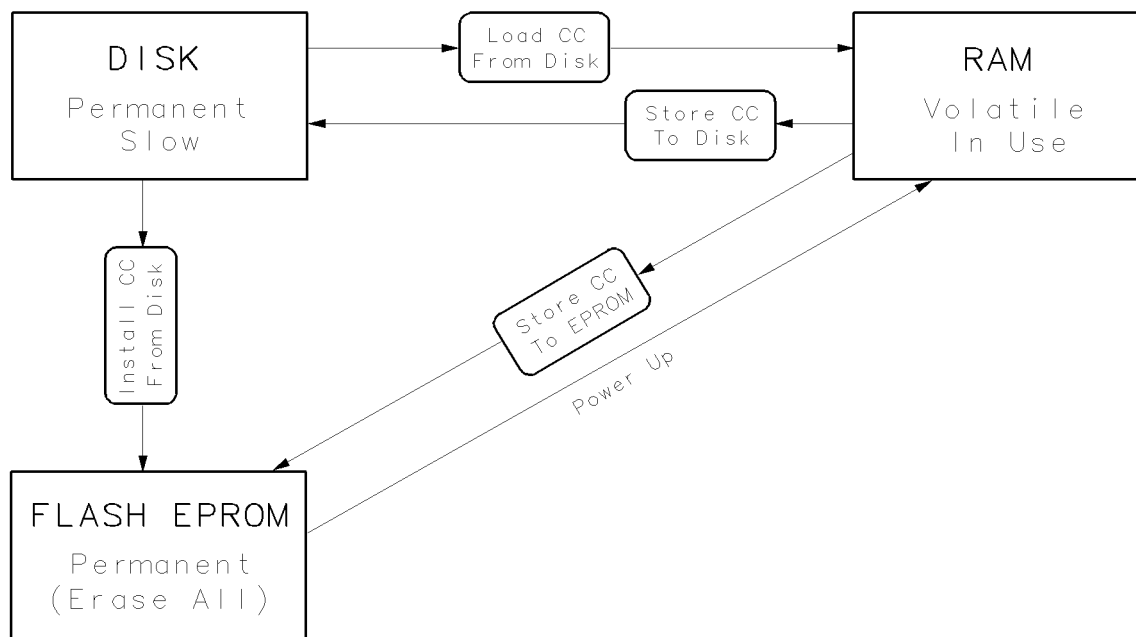

sd67b

Figure 8-1. Correction Constants Flow by Keystroke and Cycling Power

To Permanently Store CCs in the Analyzer

Typically, you have just completed the last service adjustment. The CCs are now in RAM (volatile memory). To permanently store all of the CCs in EPROM (non-volatile), perform (and check):

- step 1, (Storing Correction Constants to Disk)
- step 2, (Updating or Restoring Firmware)
- step 3, (Installing Correction Constants)

To Store CCs to Disk for Archive

Perform the following step:

- step 1, (Storing Correction Constants to Disk)

To Recall CCs from Disk

Perform the following step:

- step 4, (Loading Correction Constants from Disk)

To Recall Previous CCs from a Disk after Replacing the A2 CPU Board

Perform (and check):

- step 2, (skip this step if the A2 CPU was supplied with the correct version of firmware already installed)
- “Set Serial Number Adjustment,” in the “Adjustments” chapter, if required
- step 3, (Installing Correction Constants)

To Replace Suspected Incorrect CCs

Perform (and check):

- step 2, (Updating or Restoring Firmware)
- step 3, (Installing Correction Constants)

If ROM Appears to be Blank Message is Displayed at Power-up

Perform (and check):

- step 2, (Updating or Restoring Firmware)
- step 3, (Installing Correction Constants from Disk)

If Warning: No Correction Constants Installed Is Displayed at Power-up

Perform (and check):

- step 3, (Installing Correction Constants from Disk)

Table 8-1. Storing and Recalling Correction Constants Quick Reference

In Order To:	Perform the Following Step(s):
Permanently store CCs in the analyzer	Step 1. Storing Correction Constants to Disk Step 2. Updating or Restoring Firmware Step 3. Installing Correction Constants
Store CCs to disk for archive	Step 1. Storing Correction Constants to Disk
Recall CCs from disk	Step 4. Loading Correction Constants from Disk
Recall previous CCs from a disk after replacing the A2 CPU assembly	Step 2. Updating or Restoring Firmware (skip this step if the A2 CPU was supplied with the correct version of firmware already installed) “Set Serial Number Adjustment,” in the “Adjustments” chapter (if required) Step 3. Installing Correction Constants
Replace suspected incorrect CCs	Step 2. Updating or Restoring Firmware Step 3. Installing Correction Constants
Correct for ROM Appears to be Blank message being displayed at power-up	Step 2. Updating or Restoring Firmware Step 3. Installing Correction Constants from Disk
Correct for Warning: No Correction Constants Installed being displayed at power-up	Step 3. Installing Correction Constants from Disk

Step 1. Storing Correction Constants to Disk

1. Insert a formatted disk into the internal disk drive. (If needed, format the disk with the file utilities menu under **Save/Recal**).

Caution Do not format the correction constants disk shipped with the analyzer unless you are certain that the data on it is no longer needed.

2. Press **SYSTEM OPTIONS** **Service** **Update Corr Const** **Store CC To Disk**. The instrument writes (or overwrites) a file named “CC_DATX”. Where X is a 1,2,3 or 4 depending upon the last digit of the model number of the instrument.

Step 2. Updating or Restoring Firmware

1. Insert the firmware disk and cycle the analyzer's line power. The analyzer indicates that it detects a firmware disk and is about to install the new firmware. Press **BEGIN**.

Step 3. Installing Correction Constants from Disk

Note This step automatically loads CCs from disk and stores the CCs in EPROM.

1. Insert the correction constants disk into the internal disk drive.
2. Press **SYSTEM OPTIONS** **Service** **Update Corr Const** **Install CC From Disk**.

Step 4. Loading Correction Constants from Disk

1. Insert the correction constants disk into the internal disk drive.
2. Press **SYSTEM OPTIONS** **Service** **Update Corr Const** **Load CC From Disk**. The analyzer loads the CCs from disk into RAM.

Upgrading Firmware

To upgrade your analyzer's firmware you need two disks:

- a firmware disk and
- a correction constant (CC) disk.

Both disks are necessary because:

- Correction constants are stored in EPROM with firmware
- The old firmware must be erased before the new firmware can be stored
- EPROM can only be erased all at once (not partially)

A firmware disk is shipped with each analyzer. New firmware disks are released periodically as improvements are made. You should always keep at least one copy of firmware in a safe place because you cannot create a firmware disk yourself. See the "Parts List," chapter for the HP part number of the firmware disk.

The following is a generalized procedure. Follow the specific instructions contained in your firmware update kit.

You can use the correction constants disk shipped with the analyzer if (1) no parts have been replaced in the instrument and (2) no adjustments have been made. If, however, changes have been made, you must use a disk with the current correction constants. If such a disk is not available, follow the procedure below to make a current correction constants disk.

Making a Current Correction Constants Disk (Optional)

1. Insert a formatted disk into the internal disk drive. (If needed, format the disk with the file utilities menu under **Save/Recal**).
2. Press **SYSTEM OPTIONS** **Service** **Update Corr Const** **Store CC To Disk**.
3. Remove the correction constants disk.

How to Upgrade the Firmware

1. Insert the firmware disk and cycle the analyzer's line power. The analyzer indicates that it detects a firmware disk and is about to install the new firmware.
2. Press **BEGIN** when prompted. The firmware takes about five minutes to load.
3. Remove the firmware disk and cycle the power again. The analyzer indicates that no correction constants are installed.
4. Insert the correction constants disk.
5. Press **SYSTEM OPTIONS** **Service** **Update Corr Const** **Load CC From Disk** to load the correction constants into RAM.

Note

With some future firmware revisions, you may see a warning message indicating that the correction constants just loaded were made with a different firmware revision. In this case, it may be necessary to perform one or more additional adjustments. Press **SYSTEM OPTIONS** **Service** **Test and Adjustments** **Select Adjustment**. Cycle through the adjustments, note any that are "NOT DONE." Perform these before proceeding with the next step.

Note that adjustment #100 will always indicate "NOT DONE" and should not be performed. Refer to any specific information provided with the firmware update kit.

6. Press **Store CC To EPROM**.

Previous Serial Numbers

This guide documents the current production versions of the HP 8711B/12B/13B/14B analyzers. As future versions of the analyzer are developed, this manual may need to be modified to apply to those future versions. Information provided in this chapter will then allow you to adapt this manual to the earlier versions if necessary.

As there are presently no new versions of the analyzers, there is no information provided here at this time.

Safety, Warranty, and Assistance

Safety Symbols

The following safety symbols are used throughout this manual. Familiarize yourself with each of the symbols and its meaning before operating this instrument.

Caution Caution denotes a hazard. It calls attention to a procedure that, if not correctly performed or adhered to, would result in damage to or destruction of the instrument. Do not proceed beyond a caution note until the indicated conditions are fully understood and met.

Warning Warning denotes a hazard. It calls attention to a procedure which, if not correctly performed or adhered to, could result in injury or loss of life. Do not proceed beyond a warning note until the indicated conditions are fully understood and met.

General Safety Considerations

Safety Earth Ground

Warning	This is a Safety Class I product (provided with a protective earthing ground incorporated in the power cord). The mains plug shall only be inserted in a socket outlet provided with a protective earth contact. Any interruption of the protective conductor, inside or outside the instrument, is likely to make the instrument dangerous. Intentional interruption is prohibited.
----------------	---

Servicing

Warning	These servicing instructions are for use by qualified personnel only. To avoid electrical shock, do not perform any servicing unless you are qualified to do so.
----------------	---

Warning	The opening of covers or removal of parts is likely to expose dangerous voltages. Disconnect the instrument from all voltage sources while it is being opened.
----------------	---

Warning	The power cord is connected to internal capacitors that may remain live for 10 seconds after disconnecting the plug from its power supply.
----------------	---

Warning	For continued protection against fire hazard replace line fuse only with same type and rating (F 5A/250V). The use of other fuses or material is prohibited.
----------------	---

Warranty

This Hewlett-Packard instrument product is warranted against defects in material and workmanship for a period of one year from date of shipment. During the warranty period, Hewlett-Packard Company will, at its option, either repair or replace products which prove to be defective.

Warranty service will be performed at Buyer's facility at no charge within HP service travel areas. Outside HP service travel areas, warranty service will be performed at Buyer's facility only upon HP's prior agreement and Buyer shall pay HP's round trip travel expenses. In all other areas, products must be returned to a service facility designated by HP.

For products returned to HP for warranty service, Buyer shall prepay shipping charges to Hewlett-Packard and Hewlett-Packard shall pay shipping charges to return the product to Buyer. However, Buyer shall pay all shipping charges, duties, and taxes for products returned to Hewlett-Packard from another country.

Hewlett-Packard warrants that its software and firmware designated by Hewlett-Packard for use with an instrument will execute its programming instructions when properly installed on that instrument. Hewlett-Packard does not warrant that the operation of the instrument, or software, or firmware will be uninterrupted or error-free.

Limitation of Warranty

The foregoing warranty shall not apply to defects resulting from improper or inadequate maintenance by Buyer, Buyer-supplied software or interfacing, unauthorized modification or misuse, operation outside of the environmental specifications for the product, or improper site preparation or maintenance.

NO OTHER WARRANTY IS EXPRESSED OR IMPLIED. HEWLETT-PACKARD SPECIFICALLY DISCLAIMS THE IMPLIED WARRANTIES OF MERCHANTABILITY AND FITNESS FOR A PARTICULAR PURPOSE.

Exclusive Remedies

THE REMEDIES PROVIDED HEREIN ARE BUYER'S SOLE AND EXCLUSIVE REMEDIES. HEWLETT-PACKARD SHALL NOT BE LIABLE FOR ANY DIRECT, INDIRECT, SPECIAL, INCIDENTAL, OR CONSEQUENTIAL DAMAGES, WHETHER BASED ON CONTRACT, TORT, OR ANY OTHER LEGAL THEORY.

LIMITATION OF WARRANTY

The foregoing warranty shall not apply to defects resulting from improper or inadequate maintenance by Buyer, Buyer-supplied software or interfacing, unauthorized modification or misuse, operation outside of the environmental specifications for the product, or improper site preparation or maintenance.

NO OTHER WARRANTY IS EXPRESSED OR IMPLIED. HEWLETT-PACKARD SPECIFICALLY DISCLAIMS THE IMPLIED WARRANTIES OF MERCHANTABILITY AND FITNESS FOR A PARTICULAR PURPOSE.

EXCLUSIVE REMEDIES

THE REMEDIES PROVIDED HEREIN ARE BUYER'S SOLE AND EXCLUSIVE REMEDIES. HEWLETT-PACKARD SHALL NOT BE LIABLE FOR ANY DIRECT, INDIRECT, SPECIAL, INCIDENTAL, OR CONSEQUENTIAL DAMAGES, WHETHER BASED ON CONTRACT, TORT, OR ANY OTHER LEGAL THEORY.

Assistance

Product maintenance agreements and other customer assistance agreements are available for Hewlett-Packard products.

For any assistance, contact your nearest Hewlett-Packard Sales and Service Office.

Shipment for Service

If you are sending the instrument to Hewlett-Packard for service, ship the analyzer to the nearest HP service center for repair, including a description of any failed test and any error message. Ship the analyzer, using the original or comparable anti-static packaging materials. A listing of Hewlett-Packard sales and service offices is provided in this chapter.

Table 10-1. Hewlett-Packard Sales and Service Offices

US FIELD OPERATIONS		
<p>Headquarters Hewlett-Packard Company 19320 Pruneridge Avenue Cupertino, CA 95014, USA (800) 752-0900</p>	<p>California, Northern Hewlett-Packard Co. 301 E. Evelyn Mountain View, CA 94041 (415) 694-2000</p>	<p>California, Southern Hewlett-Packard Co. 1421 South Manhattan Ave. Fullerton, CA 92631 (714) 999-6700</p>
<p>Colorado Hewlett-Packard Co. 24 Inverness Place, East Englewood, CO 80112 (303) 649-5000</p>	<p>Georgia Hewlett-Packard Co. 2000 South Park Place Atlanta, GA 30339 (404) 955-1500</p>	<p>Illinois Hewlett-Packard Co. 5201 Tollview Drive Rolling Meadows, IL 60008 (708) 255-9800</p>
<p>New Jersey Hewlett-Packard Co. 150 Green Pond Road Rockaway, NJ 07866 (201)627-6400</p>	<p>Texas Hewlett-Packard Co. 930 E. Campbell Rd. Richardson, TX 75081 (214) 231-6101</p>	
EUROPEAN FIELD OPERATIONS		
<p>Headquarters Hewlett-Packard S.A. 150, Route du Nant-d'Avril 1217 Meyrin 2/Geneva Switzerland (41 22) 780.8111</p>	<p>France Hewlett-Packard France 1 Avenue Du Canada Zone D'Activite De Courtaboeuf F-91947 Les Ulis Cedex France (33 1) 69 82 60 60</p>	<p>Germany Hewlett-Packard GmbH Hewlett-Packard Strasse 6380 Bad Homburg v.d.H Germany (49 6172) 16-0</p>
<p>Great Britain Hewlett-Packard Ltd Eskdale Road, Winnersh Triangle Wokingham, Berkshire RF11 5DZ England (44 734) 696622</p>		
INTERCON FIELD OPERATIONS		
<p>Headquarters Hewlett-Packard Company 3495 Deer Creek Rd. Palo Alto, California 94304-1316 (415) 857-5027</p>	<p>Australia Hewlett-Packard Australia Ltd. 31-41 Joseph Street Blackburn, Victoria 3130 (61 3) 895-2895</p>	<p>Canada Hewlett-Packard (Canada) Ltd. 17500 South Service Road Trans-Canada Highway Kirkland, Quebec H9J 2X8 Canada (514) 697-4232</p>
<p>China China Hewlett-Packard Co. 38 Bei San Huan X1 Road Shuang Yu Shu Hai Dian District Beijing, China (86 1) 256-6888</p>	<p>Japan Yokogawa-Hewlett-Packard Ltd. 1-27-15 Yabe, Sagami-hara Kanagawa 229, Japan (81 427) 59-1311</p>	<p>Singapore Hewlett-Packard Singapore (Pte.) Ltd 1150 Depot Road Singapore 0410 (65) 273-7388</p>
<p>Taiwan Hewlett-Packard Taiwan 8th Floor, H-P Building 337 Fu Hsing North Road Taipei, Taiwan (886 2) 712-0404</p>		

Index

A

- A1 front panel assembly replacement, 3-2
- A2 CPU assembly replacement, 3-4
- A3 fractional-N/reference assembly replacement, 3-7
- A4 source assembly replacement, 3-8
- A5 receiver assembly replacement, 3-9
- A6 power supply assembly replacement, 3-11
- A7 display assembly replacement, 3-12
- A8 3.5" internal disk drive assembly replacement, 3-13
- absolute power accuracy specifications, 1-4
- accuracy
 - dynamic, 1-4
- adjustments
 - AM delay correction, 2-24
 - auxiliary input correction, 2-18
 - B* amplitude correction, 2-28
 - B amplitude correction, 2-22
 - external detector correction, 2-16
 - fractional-N spur, 2-6
 - fractional-N VCO, 2-3
 - frequency accuracy, 2-10
 - frequency response correction, 2-27
 - LO power correction, 2-14
 - order of performance, 2-1
 - R* amplitude correction, 2-26
 - reflection (one-port) correction, 2-25
 - relationship with correction constants, 2-2
 - required after assembly replacement, 3-14
 - set serial number, 2-12
 - source power (ALC) correction, 2-19
 - switched gain correction, 2-15
 - transmission (B/R) correction, 2-23
- AM delay correction adjustment, 2-24
- AM delay modulator replacement, 3-13
- analog bus menu, 5-10
- analog bus nodes, listing, 5-10
- array, listing, 5-8
- attenuator replacement, 3-13
- automated performance test required
 - equipment, 1-10
- auxiliary input correction adjustment, 2-18

B

- B* amplitude correction adjustment, 2-28
- B amplitude correction adjustment, 2-22
- BootROM version, 5-7

C

- calibration data arrays, view, 5-12
- category 1 failures
 - dead or no response, 4-5
 - error messages, 4-5
 - no display, 4-5
 - unreadable display, 4-5
- category 2 failures
 - other RF problems, 4-14
 - phase lock lost, 4-14
 - power output problems, 4-14
- category 3 failures
 - inaccurate data, 4-21
 - spurious data, 4-21
- category 4 failures
 - peripheral device problems, 4-24
- certification, iii
- characteristics
 - definition, 1-1
- check
 - operator's or confidence, 1-5-9
- confidence check, 1-5-9
- correction constants, 8-1
 - installing from disk, 8-1
 - making a disk, 8-5
 - relationship with adjustments, 2-2
 - storing and recalling, 8-1
- CPU (A2) assembly replacement, 3-4
- CPU assembly theory, 6-2

D

- data arrays, calibration, 5-12
- digital control theory, 6-2
- disk drive (A8) assembly replacement, 3-13
- disk drive assembly theory of operation, 6-3
- display (A7) assembly replacement, 3-12
- display assembly theory, 6-3
- documentation, additional, 7-16
- dynamic accuracy specifications, 1-4
- dynamic range
 - receiver, 1-3

E

- equipment
 - required for adjustments and automated performance tests, 1-10
- extender board
 - instructions for use, 4-2
- external detector correction adjustment, 2-16

F

- failure
 - operator's check, 1-9
- failure, types, 4-1
- firmware, 8-1
 - disks, 8-4
 - instructions for upgrading, 8-5
 - updating or restoring, 8-1
 - upgrading, 8-4-5
- firmware revision, 5-7
- fractional-N/reference (A3) assembly
 - replacement, 3-7
- fractional-N/reference assembly theory of operation, 6-4
- fractional-N spur adjustment, 2-6
- fractional-N VCO adjustment, 2-3
- frequency accuracy adjustment, 2-10
- frequency response correction adjustment, 2-27
- front panel (A1) assembly replacement, 3-2
- front panel assembly theory, 6-2

H

- hardware, screws, 7-1
- harmonics
 - specifications, 1-2
- how to order parts, 3-15
- how to use this guide, iii
- HP-IB command reference
 - for service, 5-13
 - syntax summary, 5-13

I

- installed memory, 5-7
- installed options, 5-7
- instrument history, 9-1
- instrument warranty, 10-3

L

- LO power correction adjustment, 2-14

M

- maintenance, preventative
 - 3.5" internal disk drive assembly, 3-13
- manual revisions, 9-1
- meas cal options menu, 5-10

- measurement port specifications, 1-2
- more SVC utilities menu, 5-12

N

- normal power-up sequence, 4-4

O

- operational check, 1-5-9
- operator's check, 1-5-9
- output power specifications, 1-2

P

- part number, service kit, 4-2
- parts
 - accessories, 7-15-16
 - cabinet, 7-15
 - cable locations, 7-1
 - CPU assembly, 7-4
 - CPU cable locations, 7-4
 - display assembly, 7-13
 - display assembly cables, 7-13
 - documentation, 7-16
 - documentation , 7-15
 - fractional-N/reference assembly, 7-5
 - fractional-N/reference cable locations, 7-5
 - front panel, 7-3
 - front panel cable locations, 7-3
 - fuse values, 7-12
 - how to order, 3-15
 - HP 8711B/12B:receiver, 7-8
 - HP 8711B/12B:receiver cables, 7-8
 - HP 8711B/12B:receiver cables, optional configuration, 7-9
 - HP 8711B/12B:receiver, optional configuration, 7-9
 - HP 8711B/12B:source, 7-6
 - HP 8711B/12B:source cables, 7-6
 - HP 8713B/14B optional receiver conf., 7-12
 - HP 8713B/14B optional receiver conf. cables, 7-12
 - HP 8713B/14B receiver, 7-10
 - HP 8713B/14B receiver cables, 7-10
 - HP 8713B/14B source, 7-7
 - HP 8713B/14B source cables, 7-7
 - major assembly locations, 7-1-3
 - miscellaneous mechanical, 7-15
 - order phone number, 3-15
 - power supply, 7-12
 - power supply cables, 7-12
 - rebuilt-exchange replacement assemblies, 3-15
 - screw types, 7-1
 - service tools, 7-15, 7-16
 - upgrade kits, 7-16

- parts, replacement, 7-1
- performance
 - system, 1-1
- performance test
 - software, 1-10
- performance tests
 - absolute accuracy, 1-21
 - AM delay modulator, 1-23
 - directivity, 1-22
 - dynamic accuracy, 1-20
 - frequency accuracy, 1-19
 - frequency response, broadband, 1-21
 - gain compression, 1-19
 - noise floor, 1-20
 - power flatness, 1-20
 - spurs, 1-23
- performance test software
 - file structure, 1-12
 - installation, 1-14
 - using the program, 1-17
- post repair procedures, 3-14
- power
 - absolute, 1-4
 - maximum test port, 1-2
 - output specifications, 1-2
- power supply (A6) assembly replacement, 3-11
- power supply assembly theory, 6-2
- previous serial numbers, 9-1
- probe power fuses
 - location, 3-3, 7-3
 - type, 7-3

R

- R* amplitude correction adjustment, 2-26
- rebuilt-exchange replacement assemblies, 3-15
- recalling correction constants, 8-1
- receiver (A5) assembly replacement, 3-9
- receiver assembly theory, 6-8
- receiver dynamic range, 1-3
- receiver specifications, 1-3
- receiver theory of operation, 6-6
- reflection (one-port) correction adjustment, 2-25
- replaceable parts, 7-1
- replacement procedures
 - A1 front panel assembly, 3-2
 - A2 CPU assembly, 3-4
 - A3 fractional-N/reference assembly, 3-7
 - A4 source assembly, 3-8
 - A5 receiver assembly, 3-9
 - A6 power supply assembly, 3-11
 - A7 display assembly, 3-12
 - A8 3.5" internal disk drive assembly, 3-13

- AM delay modulator, 3-13
- attenuator, 3-13
- required tools, 3-1

S

- safety, 10-1
 - cautions, 10-1
 - symbols, 10-1
 - warnings, 10-1
 - warranty, 10-3
- sales and service offices, 10-4
- SCPI commands
 - softkey, 5-14
 - summary, 5-14
- selecting an array, 5-8
- self-tests, 4-9
- service
 - sales and service offices, 10-4
 - shipment for service, 10-4
- service kit
 - contents, 4-2
 - part number, 4-2
- service related menus
 - adjustment menu, 5-5
 - analog bus menu, 5-10
 - clearing nonvolatile memory, 5-13
 - clearing SRAM, 5-13
 - introduction, 5-1
 - listing of self-tests, 5-3
 - list of adjustments, 5-5
 - meas cal options menu, 5-10
 - more SVC utilities menu, 5-12
 - self-test menu selections, 5-3
 - softkey SCPE commands, 5-14
 - tests and adjustments menu, 5-3
 - update corr const menu, 5-7
 - utilities menu, 5-8
- service tools, 7-15
- service utilities menu, 5-8
- set serial number adjustment, 2-12
- shipment for service, 10-4
- signal purity specifications, 1-2
- softkey SCPI commands, 5-14
- software
 - example programs disk, 7-15
 - firmware kit, 7-15
 - IBASIC example programs disk, 7-15
 - performance test, 1-10
 - performance test program, 7-15
- source (A4) assembly replacement, 3-8
- source assembly theory of operation, 6-4
- source harmonics, 1-2
- source power (ALC) correction adjustment, 2-19
- source specifications, 1-2

- source theory of operation, 6-4
- specifications
 - absolute power accuracy, 1-4
 - dynamic range, 1-3
 - frequency range, 1-3
 - frequency response, typical, 1-3
 - harmonics, 1-2
 - maximum input, broadband, 1-3
 - maximum input, narrowband, 1-3
 - maximum test port power, 1-2
 - measurement port, 1-2
 - output power, 1-2
 - signal purity, 1-2
 - source, 1-2
 - total power accuracy, 1-3
- specifications summary
 - definition, 1-1
- SRAM, clearing, 5-13
- static safe workstation, 4-1
- storing correction constants, 8-1
- switched gain correction adjustment, 2-15
- system impedance, 5-7
- system performance, 1-1
- system specifications summary, 1-1
- system theory, 6-1

T

- theory of operation, 6-1
 - CPU assembly, 6-2
 - differences between HP 8711/12B and HP 8713/14B, 6-7
 - digital control, 6-2
 - disk drive assembly, 6-3

- display assembly, 6-3
- fractional-N/reference assembly, 6-4
- front panel assembly, 6-2
- functional group, 6-2
- introduction, 6-1
- power supply assembly, 6-2
- receiver, 6-6
- receiver assembly, 6-8
- source, 6-4
- source assembly, 6-4
- system theory, 6-1
- transmission (B/R) correction adjustment, 2-23
- troubleshooting
 - category 1 failures, 4-5
 - category 2 failures, 4-14
 - category 3 failures, 4-21
 - category 4 failures, 4-24
 - how to use the extender board, 4-3
 - types of failures, 4-1

U

- update corr const menu, 5-7
- upgrading the firmware, 8-5

V

- verification tests
 - required after assembly replacement, 3-14
- view calibration data arrays, 5-12

W

- warranty, 10-3